



# THE EARTH OBSERVER

An EOS Periodical of Timely News and Events

Vol. 5, No. 6

November/December 1993

## Editor's Corner

### INSIDE THIS ISSUE

#### Reports

- Executive Summary—The Payload Advisory Panel 3  
Science Working Group AM-Platform Meeting 11

#### Science Team Meetings

- ASTER Science Team 17  
First International MIMR Science Advisory Group 20

#### Articles

- Total Solar Irradiance Monitoring 23  
Data Assimilation for EOS: Impact of Satellite Water Vapor Data on Precipitation Estimates 28  
Availability Of Solid Particles From The Stratosphere 31  
North Dakota Tracer Experiment Investigates Cloud Transport Processes 34

#### Announcements

- NASA Graduate Student Fellowships in Global Change Research 2  
UARS Update 10  
SAC-C Instrument Workshop 19  
USRA/GSFC Graduate Student Summer Program 22  
NOAA Global Change Postdoctoral Program 27  
DoE Global Change Postdoctoral Fellowships 33  
EOS Science Calendar 38  
Global Change Calendar 39  
The Earth Observer Information/Inquiries 38

On November 4-5, a meeting was held of the Science Working Group for the AM Platform (SWAMP), during which the algorithm development schedule, Product Generation System (PGS) Toolkit schedule, content and format of algorithm theoretical basis documents, simulated data sets, and need for a review of all scientific and calibration algorithms (levels 1B and 2) for EOS AM, were discussed in considerable detail (see SWAMP article, Page 11). It was widely accepted that the starting point for a well-developed, and widely accepted, data product for EOS was the development of an algorithm theoretical basis document (ATBD). This 30-40 page document, to be developed for each data product, should describe in some detail the granules and metadata to be included, all internal and external data product flows to be utilized, a physical and mathematical description of the algorithm, variance or uncertainty estimates, and practical considerations, such as calibration and validation, exception handling, quality control and diagnostics. Although closely related algorithms may be combined into one document, an ATBD must be prepared for each algorithm some 4-5 years before launch.

Following the preparation of an ATBD, the Project Science Office will initiate a written as well as an oral review of each algorithm. The former, which will be anonymous, with reviewers encouraged to identify themselves where they feel their comments could be extended to more constructive dialogue with the algorithm developers, will commence for the EOS AM, LIS and SeaWinds Teams in March and April (ATBDs due February 28). It is my intent to follow these written reviews with two weeks of oral presentation to a visiting committee in early May. One week will be devoted to CERES, MODIS, and MISR, with the following week devoted to MOPITT, LIS, ASTER, and



SeaWinds. Furthermore, I expect this to be a positive, constructive, and evolutionary process that should both educate as well as open discussion on substantive issues and concerns, assumptions, validation consequences, etc. The ATBD then will serve as a means to help understand and, with test results, critique the algorithm, thereby helping to assure that it is well conceived and the state-of-the-art. It will also serve as a reference to be attached to each data product and will be accessible electronically through EOSDIS. Finally, it is my intent to include not only U.S. investigators, but also foreign investigators who are developing algorithms to be incorporated into EOSDIS.

I feel that it is important to have a semi-formal review prior to software development, so that suggestions from the visiting committee and anonymous referees have the best chance of being incorporated into the algorithms being developed.

I would like to express my thanks, on behalf of the Earth Science community, for the marvelous job that Dr. Shelby Tilford has done in leading NASA's Earth Science and Applications Division and Office of Mission to Planet Earth, of pioneering international cooperation in Earth Science, and in having the foresight and insight to initiate such programs as the Upper Atmosphere Research Satellite, Earth Radiation Budget Experiment, TOPEX/Poseidon and Earth Observing System programs. I would like to extend my best wishes for his continued success in future endeavors.

Dr. Charles F. Kennel, professor of physics at UCLA, succeeded Dr. Tilford as Associate Administrator of Mission to Planet Earth, NASA Headquarters, on January 3. Dr. Kennel, a world-famous scientist renowned for his studies of space plasmas, is a member of the National Academy of Sciences, and a Fellow of the American Physical Society, American Geophysical Union, American Association for the Advancement of Science, and the International Institute of Astronautics. I would like to welcome Dr. Kennel to the Mission to Planet Earth Program, and look forward to working with him during the next couple of years in the development of a program that the entire Earth Science community can take pride in.

—Michael King  
EOS Senior Project Scientist

## Announcement

### NASA Graduate Student Fellowships in Global Change Research

NASA announces graduate student training fellowships for persons pursuing a Ph.D. degree in aspects of global change research. These fellowships will be available for the 1994/1995 academic year. The purpose is to ensure a continued supply of high-quality scientists to support rapid growth in the study of Earth as a system. Over 200 fellowships have been awarded since the inception of the program in 1990. Up to 50 new fellowships will be awarded in 1994, subject to availability of funds.

Applications will be considered for research on climate and hydrologic systems, ecological systems and dynamics, biogeochemical dynamics, solid Earth processes, human interactions, solar influences, and data and information systems. Atmospheric chemistry and physics, ocean biology and physics, ecosystem dynamics, hydrology, cryospheric processes, geology, and geophysics are all acceptable areas of research, provided that the specific research topic is relevant to NASA's global change research efforts including the Earth Observing System and the Tropical Rainfall Measuring Mission, which are a part of the Mission to Planet Earth. **THE DEADLINE FOR SUBMITTING APPLICATIONS IS APRIL 1, 1994.**

For further information contact Dr. Ghassem Asrar, NASA Headquarters, Mail Code YS, Washington, DC 20546, gasrar@sedsparc.ossa.hq.nasa.gov/Internet, phone (202) 358-0273 and fax (202) 358-2770.

# Executive Summary

## A Joint Report of The Payload Advisory Panel and The Data and Information System Advisory Panel of The Investigators Working Group of The Earth Observing System

—by **Berrien Moore III** (B.MOORE.UNH/OMNET), University of New Hampshire, Chair, EOS Payload Advisory Panel.  
**Jeff Dozier** (dozier@crseo.ucsb.edu), University of California, Santa Barbara, Chair, EOSDIS Advisory Panel.

**T**he Payload Advisory Panel of the Investigators Working Group (IWG) for the Earth Observing System (EOS) met October 4-6, 1993 in Herndon, VA. The Panel, originally composed of the Interdisciplinary Science Principal Investigators, was expanded to include all Principal Investigators and, as such, is now the IWG itself. The meeting also addressed directly a report from the EOSDIS (EOS Data and Information System) Advisory Panel.

The findings of the Herndon meeting are being issued as a Joint Report of the Payload Advisory Panel and the EOSDIS Advisory Panel. The meeting focused on payload issues in the years 2000 to 2005; however, we considered some subjects in the nearer-term, most significantly EOSDIS. The overarching theme of convergence in Earth observations set a backdrop for the entire meeting.

### **I. Convergence In Earth Remote Sensing: Implications and Opportunities for the Earth Observing System**

#### **A. Overview**

The National Performance Review\*, issued by Vice President Gore, has declared that the polar-orbiting Earth

observation satellites of the National Aeronautics and Space Administration (NASA), the National Oceanic and Atmospheric Administration (NOAA), and the Air Force's Defense Meteorological Satellite Program (DMSP) should converge into a less costly system. The EOS Payload Advisory Panel concurs that the convergence of systems offers opportunities for reductions in cost. The nation cannot afford ambitious, multiple parallel systems.

There are, however, dangers in "convergence" that would directly affect EOS and must be addressed.

- I.1. To capture the benefits of a converged system while guarding against the dangers, the EOS Payload Advisory Panel recommends retention of parallel research and operations entities, housed in either one or several organizations. Parallel, coupled research and operations entities would ensure that new technologies and techniques transfer from research to operations and that the research arm is fully aware of the highest-leverage needs of operations.
- I.2. The Payload Advisory Panel recommends that the initial steps toward convergence begin with NOAA and DMSP satellites and their associated

\* Editor's Note: The Report of the National Performance Review carries the formal title: "From Red Tape to Results; Creating a Government that Works Better and Costs Less;" author is Vice President Al Gore; and the date is September 7, 1993. Relevant to the presentation here is recommendation DOC 12 to the U.S. Department of Commerce, which reads: "Establish a Single Civilian Operational Environmental Polar Satellite Program. To reduce duplication and save taxpayers a billion dollars over the next decade, various current and proposed polar satellite programs should be consolidated under NOAA."

ground systems. The initial focus should be on joint management and operations. The consolidation should be under the civil entity.

If the NOAA-DMSP convergence takes place, further mergers with NASA activities can be examined. As with the initial convergence, the merger should begin by creating a common management structure and satellite ground systems.

- I.3. The Payload Advisory Panel does not now advise where such a converged system should locate in the federal government, other than stating that the consolidation should be within civil entity(ies). The institution(s) must fully support and be charged with the long-term, essentially permanent, observation of the Earth for research and applications. The converged system must accommodate the scientific needs for long-term, calibrated data, as well as an observational strategy that is flexible enough to address unforeseen issues in Global Change and to exploit advances in technologies.

The timing of convergence greatly affects the realized cost savings. NOAA and DMSP have enough instruments and satellites currently in production to carry observations to about 2002-2004. The METOP-1 satellite of the European Organization for the Exploitation of Meteorological Satellites (EUMETSAT) will launch in late 2000 with a 5-year design lifetime in a polar orbit with a morning crossing and will carry NOAA operational instruments. The EOS PM-1 afternoon polar-orbiting spacecraft will launch in 2000, also with a 5-year design lifetime. The first spacecraft that convergence would affect are the NOAA and DMSP afternoon-orbiting satellites starting about 2002-2004. The next spacecraft would be the EOS AM-2, EOS PM-2, and METOP-2 in 2003-2005. Savings on management, operations, and data processing could begin somewhat sooner.

- I.4. The Payload Advisory Panel will carefully reconsider the AM-2, PM-2, and Chem-2 payloads, considering convergence, the need for long-term measurements, and the growing recognition of the need for a robust, flexible observational strategy. This strategy must build on EOS AM-1, PM-1, and Chem-1, on NOAA TIROS, and on DMSP, and it must recognize explicitly the con-

tributions and needs of our international partners.

### **B. EOS PM-1 Mission: A Stepping Stone to Convergence**

The Payload Advisory Panel recognizes the central role that the EOS instruments have in convergence, especially the several EOS PM-1 instruments that are candidates for operational roles with either NOAA and/or EUMETSAT in the EOS PM-2 era. As a contribution to the convergence discussion, the Panel considered each of the EOS PM-1 platform instruments and their possible role in a converged system.

The Atmospheric Infrared Sounder (AIRS) will meet all scientific and operational requirements for an infrared sounding capability as defined by NASA and NOAA. NOAA has been involved from the outset in helping set the instrument requirements for spectral coverage and resolution, detector sensitivity, and data rates. Most importantly, in 1992 AIRS was descoped from a two-spectrometer design to a single spectrometer partly in response to NOAA requirements.

- I.5. The Payload Advisory Panel recommends that NASA, EOS, and the AIRS Project continue to involve NOAA in all aspects of the AIRS and to raise and resolve all specific issues and concerns as they arise. We strongly encourage the involvement of ESA, EUMETSAT, and DoD. We reiterate our earlier recommendation that AIRS move to operational status in about 2005.

There is a danger that the Microwave Humidity Sounder (MHS) will not be available for the EOS PM-1 payload. This would be a serious blow to the science; moreover, the loss of MHS from EOS PM-1 would prevent NOAA from testing the full three-instrument suite, AIRS-AMSU-MHS, as a pre-operational system.

- I.6. The Payload Advisory Panel strongly recommends that NASA acquire an MHS (or AMSU-B) instrument for flight on the PM-1 platform.

The science needs of NASA for passive microwave imagery can be met with an instrument that is currently being designed for both operational and scientific purposes by the European Space Agency (ESA). This instru-



ment, the Multifrequency Imaging Microwave Radiometer (MIMR), follows the heritage of the Special Sensor Microwave Imager (SSM/I) on the DMSP spacecraft. A MIMR-class instrument is needed both for operational and research interests.

- I.7. The Payload Advisory Panel recommends that a joint NASA/NOAA/DoD study team work closely with ESA, EUMETSAT, and the MIMR Science Advisory Group and reflect any additional operational requirements that could contribute to improving the long-term utility of MIMR and passive microwave observing generally.

The Moderate Resolution Imaging Spectroradiometer (MODIS) provides key Global Change observations of cloud physical properties, aerosols, ocean color, ocean surface temperature, and land surface properties including vegetation, snow cover, and skin temperature. MODIS supplies data for many of the needs of the atmosphere, land, and ocean sciences.

- I.8. The Payload Advisory Panel recommends that NASA work cooperatively with NOAA, DoD, and ESA/EUMETSAT to refine the requirements for a well-calibrated MODIS-class imaging radiometer that will simultaneously meet the needs of the Global Change and operational communities. This process will have to consider costs of the full system and accommodation issues as well as ESA's MERIS instrument.

Accurate measurements of radiative fluxes and of cloud properties are critical to solving problems connected with global climate change. The contribution of the Clouds and the Earth's Radiant Energy System (CERES) instrument to the retrieval of radiative fluxes is well documented, based on the experience of the Earth Radiation Budget Experiment (ERBE).

- I.9. Because of the strong need for simultaneity between the cloud measurements and the radiative flux measurements, the Payload Advisory Panel recommends that MODIS, CERES, and MIMR instruments fly on the same platform.

The CERES instrument and software are being developed with full interaction with NOAA, who will have near real-time (within 2-3 hours) access to the CERES data for use

in operational forecasts. Although NOAA has informally expressed an interest in obtaining CERES measurements for operational radiation budget fluxes and cloud forcing, DoD is unlikely to have a requirement for the CERES observations.

- I.10. The Payload Advisory Panel recommends that NASA, EOS, and the CERES Project continue to involve NOAA, and where appropriate, ESA and EUMETSAT, in all aspects of the CERES instrument and software development and to raise and resolve all specific issues and concerns as they arise.

### C. Convergence Summary

The EOS Payload Advisory Panel concludes that while convergence may provide long-term cost savings, a phased approach will best combine savings and system robustness. Efforts to merge management, spacecraft command and control, and data processing must precede convergence of spacecraft and instruments. A clear separation of operations and R&D must be maintained, including some expansion capability in both operational and research spacecraft designs to allow for unexpected changes in requirements while maintaining the cost efficiency of purchases of multiple units. Finally, any converged system must meet the requirement for highly calibrated, long-term, continuous measurements for EOS satellite observations in support of the U.S. Global Change Research Program (USGCRP).

## II. Atmospheric Chemistry: EOS Chem and EOS Aero

### A. EOS Chem-1 Mission

The Payload Advisory Panel is convinced that the EOS Chem-1 Mission will provide a comprehensive series of measurements that address key science questions in three critical areas: climate change, ozone depletion, and the changing chemistry of the troposphere. The Payload Advisory Panel believes, however, that a few important changes in the EOS Chem-1 Mission can significantly and cost-effectively improve the scientific return.

- II.1. The Payload Advisory Panel recommends that ACRIM fly before EOS Chem-1 to avoid data gaps that will reduce the scientific value of the ACRIM

data set. The Panel requests that NASA aggressively explore the possibility of refitting the ACRIM ATLAS instrument for early flight (1996-1998) on a longer-duration spacecraft. Possibilities include a small spacecraft, the NOAA TIROS Series, and either EOS AM-1 or PM-1.

We note that ACRIM need not fly on any particular EOS platform, including EOS Chem-1. ACRIM simply needs to fly on a series of spacecraft that will allow the development of a long-term, continuous record of solar variability.

The EOS Chem-1 payload measures the set of atmospheric chemistry and aerosol variables identified by the EOS Atmospheres Panel as essential to monitor the chemical, aerosol, and radiative processes that control ozone.

II.2. The Payload Advisory Panel continues to endorse the measurement of OH as provided by the enhanced MLS. OH is a key radical controlling ozone loss in the lower stratosphere and is a critical component in the monitoring strategy of EOS Chem-1.

II.3. The Payload Advisory Panel endorses the UARS-equivalent SOLSTICE II instrument for long-term accurate UV flux measurements. Regrettably, in the constrained budget environment, the Panel is unable to recommend the SURE option. This enhancement would improve greatly our understanding of the Sun-Earth connection, but its particular contribution to clarifying issues of Global Change is less central. We note that flight of SOLSTICE II on the EOS Chem-1 Platform is not essential for any other instrument; therefore, SOLSTICE II could fly on another spacecraft in the 2002-2004 time frame if another option proves more affordable.

II.4. The Payload Advisory Panel endorses the New TOMS instrument that NASDA will provide as the CII (Chemistry International Instrument) contribution to the EOS Chem-1 Payload. New TOMS will continue the long-term, high-quality column ozone measurements made by the NASA TOMS instruments before the launch of EOS Chem-1.

The Payload Advisory Panel recognizes that scientific issues associated with tropospheric chemistry are high on

the list of national and international priorities. The Mission to Planet Earth can respond better to those priorities by moving TES forward from AM-2 to Chem 1. Similar lower stratospheric and upper tropospheric data from HIRDLS, MLS, and SAGE III provide a strong synergism because all four instruments will measure key trace gases at altitudes from 10 to 25 km. The combined data enhance science and allow for important intercomparisons among instruments. In addition, the New TOMS will also provide important information on the changing chemistry of the troposphere. When combined with HIRDLS, MLS, or SAGE III data, New TOMS data can be used to derive tropospheric ozone, increasing the synergism with TES on the EOS Chem-1 Platform

II.5. The Payload Panel strongly recommends moving TES from EOS AM-2 to EOS Chem-1.

### B. EOS Aero Mission and SAGE III

SAGE III, in a mid-inclination orbit, along with SAGE III on EOS Chem-1, yields the required global coverage for its long-term, self-calibrating measurements.

II.6. The Payload Advisory Panel reiterates its recommendation for an early flight of SAGE III in a mid-inclination orbit (56°-73°) to continue the measurements by the SAGE series. The Panel notes with concern that NASA has neither identified nor budgeted a spacecraft for Aero, the mid-inclination mission, in the EOS program.

### C. Relation to ENVISAT I and II

The Payload Advisory Panel accepted a launch of the EOS Chem-1 Mission after the year 2000 because of fiscal constraints and because of the recognition that ESA's ENVISAT I Mission could provide key measurements of important chemical species in the atmosphere throughout 1998-2002.

II.7. The EOS Payload Advisory Panel strongly supports our European colleagues in implementing the technically challenging and scientifically important ENVISAT I Mission.

ENVISAT is a crucially important international component in the effort to understand global environmental change. Understanding and coping with this issue clearly exceeds

the capabilities of any one nation; it is a global problem and will require global responses.

- II.8. The Payload Advisory Panel will continue seeking to foster the necessary cooperation and coordination between NASA and its domestic and international partners. The Payload Advisory Panel extends its appreciation for the spirit of cooperation and good will shown by all of our international partners.

### III. Remote Sensing of the Global Cycles of Energy, Water, and Carbon in EOS

The EOS AM-1 payload will provide us with a vastly improved observation and understanding of the global cycles of energy, water, and carbon, particularly over the continents. The AM-1 Mission will provide surface boundary conditions for calculating the surface-atmosphere fluxes of energy, water, and carbon on short (seconds to interannual) time-scales.

Recently, some progress has been made in our understanding of the global carbon cycle. This progress and its implications will be reflected in the upcoming 1994 Assessment of the Intergovernmental Panel on Climate Change (IPCC).

#### A. The Carbon Cycle: Implications for Land Remote Sensing

Human-induced changes to the global carbon cycle are one of the most significant drivers of Global Change. Future concentrations of atmospheric CO<sub>2</sub>, the proximate forcing for climate and vegetation changes, are a function of sources such as fossil fuel burning and deforestation and of sinks in the oceans and land vegetation and soils. There are three terms in the terrestrial carbon budget that must be considered, each requiring a somewhat different remote sensing strategy.

1. First are the annual, nearly balanced, fluxes of CO<sub>2</sub> into the biosphere (photosynthesis) and into the atmosphere (plant and soil respiration), with some interannual variability caused by the El Niño Southern Oscillation (ENSO), major droughts, and other climate anomalies. EOS scientists have articulated a clear strategy for estimating global photosynthesis, relying primarily on MODIS and MISR to capture

seasonal and interannual variability in the large-scale dynamics of vegetation.

2. Second, land use changes, particularly deforestation in the tropics, cause a release of CO<sub>2</sub> to the atmosphere. Satellite measurements of forest clearing rates are a first-order requirement for quantifying the carbon fluxes associated with land clearing. The work by the Brazilian National Space Agency (INPE) has shown significant interannual variability in rates of deforestation. To measure such variations, we need coverage annually or at least every other year. The EOS Landsat Pathfinder activity has shown that Landsat-5 spatial and spectral resolutions are ideal for large-scale mapping of vegetation changes.

III.1. The Payload Advisory Panel states strongly that the programmatic structure for Landsat must provide data for Global Change priorities. Convergence of systems must not obstruct acquisition of these important data. This is ever more urgent with the failure of Landsat-6 to reach orbit and the fragile condition of Landsats-4 and -5.

III.2. The Payload Advisory Panel and EOSDIS Advisory Panel jointly recommend a thorough independent review of the estimated cost of the data system for Landsat-7, including data processing for the Enhanced Thematic Mapper (ETM) and High-Resolution Multispectral Instrument (HRMSI).

3. Third is the problem of the "missing sink." The missing sink is commonly assumed to be linked to the increase in atmospheric CO<sub>2</sub>, although changes in the age structure of forests caused by intense mid-latitude harvesting in the late 1900s and atmospheric deposition of nitrogen also play a role. The issue is central to the determination of the atmospheric lifetime of CO<sub>2</sub>; the questions are open and important.

A promising avenue for measuring these changes in ecosystem physiology is through the remote sensing of canopy chemistry. The only proposed approach to measuring canopy chemistry on adequate spatial scales is through spectrometry at high spectral resolution. The recent empirical studies of the Accelerated Canopy Chemistry Program (ACCP) provide encouraging empirical and

some theoretical evidence that space-borne spectrometers will provide considerable information on canopy chemistry.

- III.3. The Payload Advisory Panel recommends that funding for the HIRIS team, at least that portion central to the current focus of canopy chemistry, be continued through the successful conclusion of the HIRIS Team's Accelerated Canopy Chemistry Program (ACCP).
- III.4. The Payload Advisory Panel further recommends that the final report of the HIRIS Team's ACCP be carefully peer reviewed. If the report and the review are positive about the potential, scientific utility of this technology, then NASA might develop a relatively modest, space-borne mission for the 1999-2002 period to advance the technological and scientific base. To accommodate this possibility, the planning for this mission should begin now.

This experimental, low-cost mission should be part of the Earth Probes program and use a small launch vehicle and low orbit; the latter would allow a significant savings through the use of smaller optics.

### **B. Remote Sensing of the Land in the EOS Era: EOS AM-2, EOS PM-2, and Landsat-7/8**

If TES is moved from the AM-2 platform to Chem-1, then we should carefully consider placement of a land-surface imaging system on the AM-2 platform that would strongly complement the simultaneous viewing with MODIS and MISR. The requirements of this land-observing instrument suite need to be defined in the context of the discussions for the Advanced Land Remote Sensing System (ALRSS), the results anticipated from ASTER and SPOT, which do not adequately address the required coverage, and the ACCP efforts in the use of hyper-spectral imagery.

- III.5. The Payload Advisory Panel recommends a careful reconsideration of the high-resolution land remote sensing strategy for the EOS AM-2 era and beyond. This strategy must consider not only the scientific demands and potential payloads but also the issues of convergence and the contribution of international partners.

We are especially concerned with current arrangements for "reconciling" the needs of the Global Change research community and of the defense community in the design and operation of the ALRSS. We are also particularly concerned about the high cost of the Landsat program, particularly Landsat-7 and its data system. See also Recommendations III.1 and III.2.

## **IV. Ocean And Land-Ice Altimetry: EOS Alt**

The science objectives of EOS Land-Ice Altimetry and EOS Ocean Altimetry dictate that these sensors be on separate spacecraft.

- IV.1. The Payload Advisory Panel recommends that the Project proceed with plans for separate EOS spacecraft missions for land-ice altimetry and ocean altimetry.

### **A. Ocean Altimetry**

The global sea surface topography currently being measured by the TOPEX/Poseidon Mission is of unparalleled accuracy and is providing a critically needed ability to monitor accurately the global oceans at a temporal resolution of 10 days. These data provide new opportunities for monitoring ocean phenomena and developing models to predict long-term Global Change. It is imperative that this measurement series be continued beyond the current TOPEX/Poseidon Mission.

- IV.2. The Payload Advisory Panel recommends that the EOS Program and Project explore options for ensuring that the important measurements provided by the current TOPEX/Poseidon mission be continued to bridge the gap between the end of TOPEX/Poseidon and the launch of EOS Ocean Alt.

Two options are feasible:

1. The TOPEX/Poseidon Follow-On (TPFO): This mission, to be conducted jointly with Centre National d'Etudes Spatiales (CNES) and NOAA for a launch in 1998, is the preferred option because it would be compatible with actual TOPEX measurement performance. This option must, however, face a significant budget hurdle. It would require a New Start and a



budget commitment in 1995. This budget commitment would be external and in addition to the current EOS program.

2. The GEOSAT Follow-On (GFO): This Mission is currently being developed by the United States Navy for launch in 1996. For this to be a viable "Gap Filler," several changes would be necessary in order to meet the EOS Science Objectives:
  - a. add dual-frequency altimeter to correct for ionosphere;
  - b. transmit full waveform data;
  - c. boost sampling rate of altimeter to reduce noise;
  - d. add laser retro-reflector cubes for ground tracking and calibration and validation;
  - e. release all tracking data to the civilian community, and
  - f. keep the international TOPEX/Poseidon Science and Data Processing team in place.

In addition, it would be preferable if the orbit were consistent with TOPEX/Poseidon.

IV.3. The Payload Advisory Panel recommends that NASA vigorously explore the GFO option because of the difficult budget environment. However, the TPFO option is the most desirable bridge to the EOS Ocean Alt.

### B. Land and Ice Altimetry

1. Land-Ice Altimetry: The Geoscience Laser Altimeter System (GLAS) is the essential instrument for polar ice sheets, whose mass balances affect predictions of global sea level change, a key IPCC issue of scientific uncertainty.

IV.4. The Payload Advisory Panel recommends that strategies be explored for advancing the launch date of the GLAS instrument.

2. GPS Geoscience Instrument: In view of the continuing problems with GPS signal restriction (anti-spoofing), and the importance of the GPS to EOS Alt missions,

IV.5. The Payload Advisory Panel recommends that

the GPS Geoscience Instrument (GGI) team focus on developing the codeless receiver technology.

3. Tracking and Data Relay Satellite System: The use of the Tracking And Data Relay Satellite System (TDRSS) has a significant negative impact on the cost and design of small spacecraft. This could directly impact the EOS Alt Missions.

IV.6. The Payload Advisory Panel recommends that NASA assess the relative advantages and disadvantages of TDRSS, particularly for the smaller EOS platforms, before enforcing a hard TDRSS requirement. The assessment must consider the full system, including both the space and ground segments.

## V. The EOS Data and Information System

### A. The State Of The System

The three-year blackout surrounding the procurement of the EOSDIS Core System (ECS) contractor has ended, and, in March 1993, NASA selected Hughes Applied Information Systems (HAIS) as the primary contractor. In the interval, EOS itself has changed substantially, hence the requirements of the information system have changed. The EOS IWG and its EOSDIS Advisory Panel had their first views of the revised requirements, architecture, and design of EOSDIS in September 1993.

We have high hopes for a system that will provide us with easy, affordable, and reliable access to EOS information and other appropriate Earth science data in a modern computing environment throughout the next 2 decades. However, we now see a danger that the system may not have essential attributes we had envisioned. There are fundamental flaws in the current architecture and design and in the plans for implementation. The Project and Contractor are now working on a new architecture.

The currently proposed system must have strong connectivity to the user community and embrace a problem-solving approach to EOSDIS development. It must avoid becoming mired in details of fulfilling "requirements" without a high-level vision of the fundamental attributes of a successful data system. The Project, Contractor, and the proposed information system must show adequate

adaptability to function in a user-driven, evolutionary environment. If EOSDIS is to be successful, then its architecture, design, and implementation require substantial changes, which are now in progress.

### B. Recommendations

- V.1. The EOS Payload Advisory Panel and the EOSDIS Advisory Panel strongly recommend that NASA work with the user community to fix EOSDIS. Furthermore, it must respond to comments from the National Research Council's Panel to Review EOSDIS Plans.
- V.2. More specifically, the EOS Payload Advisory Panel and the EOSDIS Advisory Panel recommend the following actions, in priority order:
  - a. Rewrite the Requirements Specification.
  - b. Embark on studies of alternative architecture.
  - c. Strengthen the awareness of users' needs within the Project and Contractor.
  - d. Create a logical distribution of EOSDIS.
  - e. Fund a vigorous and independent prototyping program.
  - f. Focus on the needs of the science community.
  - g. Identify key people and assign responsibilities.
  - h. Become more aware of non-governmental data systems.
  - i. Increase coordination with other NASA projects.

### C. Closure

For the next few months, we need to be patient and give the Project and the Contractor a chance to begin to solve these problems. We need to have confidence that they can respond.

We must not wait indefinitely. NASA must fix EOSDIS soon. If we do not see substantial improvement by January 1994, if we do not have confidence that EOSDIS is on the road to recovery by then, we must take more significant steps.

We proposed an informal system review—revised requirements, cost breakdown, architecture, design, and plans for maintenance and operations—before the next meeting of the EOS IWG, January 11-13, 1994. The system review was conducted December 13-14, 1993 with mem-

bers of the EOSDIS Advisory Panel and a larger group of representatives from NASA HQ, EOSDIS Project, the Contractor, and the information science community. From the evidence presented at this review, the EOSDIS Advisory Panel is evaluating the leadership of the EOSDIS Project and Contractor and their commitment to evolution, distribution, creativity, excellence, and economical operation. Our initial reaction is positive.

- V.3. At the January 1994 IWG meeting, the IWG will hear a report from its EOSDIS Advisory Panel and make recommendations to NASA about directions for EOSDIS. ■

EOS.News — Friday, December 10, 1993

## UARS UPDATE

Normal operations have been resumed on the Upper Atmosphere Research Satellite (UARS) following a successful solution to problems with the solar array drive on October 21, when the A-side drive was placed in neutral and the B-side drive was engaged. The entire first year of MLS Level 3 data (9/91 to 9/92) has now been transferred to the Distributed Active Archive Center (DAAC) at NASA Goddard Space Flight Center (GSFC). The GSFC DAAC will soon make available Solar Stellar Irradiance Comparison Experiment (SOLSTICE) Level 3BS data (solar spectra with instrument degradation folded in), followed by ISAMS Level 3 data products and Halogen Occultation Experiment (HALOE) data sets. The remaining data will be released in 3-month intervals. For information on ordering data, contact GSFC DAAC User Services, Code 902.2 NASA/GSFC, Greenbelt, MD 20771, tel. 301-286-3209; daacuso@daac.gsfc.nasa.gov. Plans are being made for several UARS results special- journal issues, including the Journal of the Atmospheric Sciences.

# Science Working Group AM-Platform Meeting

November 1993 SWAMP Meeting Held at Goddard

—by Philip Ardanuy (PARDANUY/GSFCMAIL), Research and Data Systems Corp.

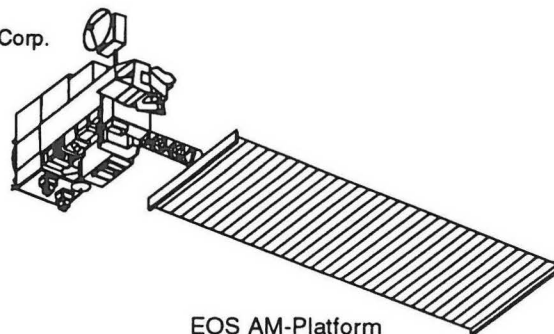

EOS AM-Platform

The Science Working Group, AM-Platform (SWAMP), was formed to explore issues common to all EOS Instrument Teams and also of interest to Interdisciplinary Investigators. On November 4-5, 1993, the SWAMP met at Goddard Space Flight Center. It was jointly chaired by Piers Sellers (EOS-AM Project Scientist) and Chris Scolese (EOS-AM Project Manager). Held to an aggressive agenda, the meeting covered the following issues:

- Instrument Status Updates
- Platform Pointing Status
- Digital Elevation Model and Merged/Advanced Products
- Calibration and Validation
- Algorithm Development

Scoles gave an update of the AM Project. Preliminary Design Reviews (PDRs) are essentially done; Critical Design Reviews (CDRs) are underway. We have also passed the spacecraft PDR. Kinematic mounts and cold plates have been shipped to Japan for ASTER instrument use. The PDR-level jitter analysis has been completed. The MODIS ghosting problem has been successfully resolved, and the CERES noise problem has been resolved as well. MISR has been reconfigured to reduce mass growth. The in-house capillary flight experiment (CAPL) was shipped to Kennedy Space Center (KSC) for a January 1994 space shuttle flight. Lewis Research Center has released the intermediate-class launch vehicle request for proposal (RFP).

Near-term milestones include completing and baselining science software statements of work, and launch vehicle

selection by Lewis. Several issues were reviewed, including the need to work with multiple interfaces as no launch vehicle has yet been selected, resolution of issues coming from ASTER's PDR, and NASA's Office of Space Operations' withdrawal of flight dynamics support and NASA's Compatibility Test Van support.

## INSTRUMENT STATUS UPDATES

### MODIS

John Barker provided an update on MODIS instrument status. The ghosting issue has been successfully solved with a prefilter and special anti-reflection coatings. It was caused by the interaction of increased instrument sensitivity and the inadvertent creation of a new image on each focal plane from rejected light reflected from lens surfaces. Ghosting and stray light budgets of 1% are now included within MODIS accuracy budgets.

Should spectral shifts of 10 nm occur, they would exceed the signal-to-noise ratio (SNR) by a factor of 2 but this is correctable through the solar diffuser. Bands 17 and 18 (a water vapor band) are particularly sensitive, but the presence of the Spectro-Radiometric Calibration Assembly (SRCA) on this instrument to characterize spectral shift in-flight will address this.

### MISR

Dave Diner said that MISR's first charge-coupled device (CCD) is to be delivered this month. Its quantum efficiency is 30%, vs. the 7% available with conventional

technology. A full-scale MISR mock-up has been built and is being used. Parts for the engineering model are under fabrication. Algorithm Theoretical Basis Documents (ATBDs) for calibration and navigation are being completed. TM data are being used to create a simulated MISR dataset.

MISR is overweight (151 kg at PDR vs 135 kg allocated for launch), but this has been reduced by relocating the electronics. Power requirements and data rate are within limits. However, use of MISR's local mode (full-resolution) can exceed the peak data rate allocation under certain conditions.

MISR is concerned about two potential sources of glint: the DAS antenna and CERES. MISR could deploy a glint baffle to block this. However, this could raise two problems: MISR radiator efficiency and a new source of stray light for CERES.

### *CERES*

Bruce Barkstrom said that CERES will be capable of obtaining a stability of 0.5% per 5 years based on lessons learned from ERBE.

### *ASTER*

Fujisada said that major spacecraft PDR issues are that ASTER's shortwave infrared telescope Stirling Cycle cooler prevents the spacecraft from meeting pointing stability requirements, and that ASTER is yet not compliant with T2P (time to transfer two data packets) in the General Instrument Interface Specification (GIIS).

ASTER is currently in the engineering model fabrication phase. Kinematic mounts and cold plates for the engineering models were delivered to Japan. The ASTER Memorandum of Understanding (MOU) is being renegotiated between U.S. and Japan.

### *MOPITT*

John Gille described MOPITT's PDR. Instrument changes include fully refractive (rather than fully reflective) optics, which should provide better alignment. To collapse its length, MOPITT now has a roof mirror in its reversing optics instead of a prism. MOPITT's optics are deliberately defocused to eliminate scene twinkling. Its performance calculations have been updated using the latest spectral

line data, with two line-by-line calculators. Results are in agreement, and show that the atmosphere will produce more signal than initially expected.

### **PLATFORM POINTING STATUS**

The pointing knowledge issue had been flagged during the previous SWAMP meeting. Diner presented requirements derived from a platform pointing study. Input was received from Martin Marietta and the EROS Data Center. In terms of nadir geolocation requirements, ASTER, MISR, and MODIS are affected, but not CERES or MOPITT. The requirements were presented in relative image registration and absolute location accuracy.

Paul Westmeyer reviewed current platform pointing status. The TDRSS On-board Navigation System (TONS) position data should exceed specifications. The instruments themselves are the dominant factor in jitter. House-keeping disturbances are being tracked, and optical paths for each of the instruments are being incorporated into an optical model by Goddard Space Flight Center.

The term "dead reckoning" refers to planned navigation of instrument line-of-sight based on the best knowledge of platform and instrument position and attitude. Dead reckoning does not have sufficient accuracy to meet the AM spacecraft instrument requirements even if instrument pointing knowledge is perfect. To successfully navigate EOS instrument data, we must remove static biases in flight. The MISR requirement will be met, and MODIS almost met, using dead reckoning. ASTER requirements will not be met. Alternatives to dead reckoning include optical navigation and reference image correlation. These were considered poor alternatives. ASTER will do reference image correction anyway, but MISR and MODIS would do this only if dead reckoning failed. The MODIS platform stability requirements are loose and do not constrain the platform to any degree needed for either approach. Finally, angular displacement sensors (ADS) to measure high-frequency displacement components should be considered for the platform, (as done with the Landsat Thematic Mapper. This question will be pursued for MODIS, MISR, and ASTER. Scolese indicated that the uncertainties apply to estimated values, stating that, "we guarantee that, if everyone comes in at their specification, we will meet our over-spacecraft specification."

Westmeyer and Tom Venator concluded that while the jitter model predictions were the best available and would



improve with time, the uncertainty in the current error estimates could be as large as a factor of three or even five, requiring conservative planning at this stage.

Sellers directed Diner and Westmeyer et. al. to collaborate on a short summary of this issue for distribution, with the utility of angular displacement sensors specifically addressed.

### **DIGITAL ELEVATION MODEL (DEM) AND MERGED/ADVANCED PRODUCTS**

#### *DEM*

Sue Jensen stated that there will not be a single consistent Digital Elevation Model (DEM) at launch that meets all requirements. We must, therefore, review our needs and come up with the best possible approach. DEM test databases should be formalized.

Jensen, Sellers, and SWAMP will produce a letter for Michael King's signature reasserting our need for high-quality DEM availability to meet EOS science requirements, specifically the DTED data.

#### *Gridding*

Jim Stobie said that the near-term gridding goals should be to: make data useful to the widest possible range of users; make grids compatible with important historical datasets (e.g., NMC and ECMWF); and make data useful to interdisciplinary investigators. The Goddard Data Assimilation Office (DAO) will access Level 1 and Level 2 data on a proposed 1° latitude/longitude grid as an EOS standard. Advantages include no loss of information for DAO by interpolation, and easy transformation to other grids. The DAO group will report on further progress of the standard gridded product concept at the IWG.

Mike Botts reviewed the Pathfinder Interuse Experiment. Interusability is the ease with which datasets from various sensors and disciplines can be brought together, coregistered in space and time, correlated, analyzed, and visualized together with scientific tools. Minimum loss or corruption of scientific information is of vital importance. The interuse experiment will distribute selected Level 2 data and gridding/transformation tools, and then study resultant issues relating to the interuse of Level 2 and Level 3 datasets.

Blanch Meeson reviewed the gridding approach adopted by ISLSCP. A uniform dataset of diverse variables including radiative, land surface, clouds and radiation will be released on CD-ROM in June 1994.

#### *Clouds and Cloud Masks*

As described by King, cloud utility mask development is being undertaken by Paul Menzel, King, and Barker on the MODIS Team, and Ron Welch and Bryan Baum from CERES. Menzel will take the lead in putting together a mask ATBD by early 1994. The algorithm will combine Menzel's thermal-IR expertise, King's near-IR expertise, and Welch's polar cloud/sea ice and AI expertise. King and/or Barker will integrate this as a combined modular approach. King and Diner emphasized that this MODIS product must be available early, as other instruments will depend on it.

#### *Cloud Predictability for ASTER*

Philip Ardanuy reviewed the utility of cloud forecasting for ASTER Data Acquisition Request (DAR) planning and scheduling. Both 24- and 48-hour forecasts were tested. Cloudiness was predicted successfully 79% of the time at 24 hours, and 75% of the time at 48 hours, representing improvement over raw NMC model predictions. Added familiarity with the local forecasting problems of the various sites would reasonably be expected to raise this success rate; this would mean success for five of every six forecasts and indicates that ASTER planning and scheduling could benefit by explicitly accounting for predicted cloud cover.

#### *Sun Angle Dependence*

Forrest Hall identified a Sun-angle-dependent feature expected to be present in EOS Fractional Photosynthetically Active Radiation (FPAR) and Leaf-Area Index (LAI) products. Ground truth of LAI shows agreement only for the minimum days from the AVHRR 9-day cycle, and not for the large excursions that occur for viewing geometries on other days. The AVHRR geometry and effects will be mirror-imaged in EOS-AM.

### **CALIBRATION AND VALIDATION**

#### *Calibration Update*

Bruce Guenther discussed upcoming peer reviews to be held 3 to 4 months following the individual instrument's

CDRs, and will focus on Level 1 calibration. A set of round-robin cross-calibration plans are being put in place. ASTER will have integrating spheres in 1994. The round-robin process will begin in June/July 1995, consistent with delivery of the engineering models. Analyses will begin with the visible/near-IR bands.

Unless instruments come into spacecraft integration dirty, Guenther does not expect to find contamination problems any worse than with UARS.

Guenther also reviewed the status of lunar calibration work. Lunar calibrations provide an inexpensive opportunity to validate the Modulation Transfer Function (MTF) on orbit; they offer a stable target and provide the ability to map near- and far-field responses with a 0.5° source.

Westmeyer followed with the AM Project's position on lunar observations. The Project is comfortable doing a 20° roll, so that MODIS could see past the Earth's limb and view the Moon. This is fairly benign from a spacecraft point of view. There followed vigorous discussion, which ended with Barker agreeing to address the benefits of 20° versus full roll, and Westmeyer to address risks.

*Validation Update*

Michael King will set up a Validation Panel at the IWG which is separate from the previously established, combined Calibration/Validation Panel.

Barkstrom discussed potential comparison and consistency checks. Possible pixel-level intercomparisons include: (1) ASTER averaged to MODIS; (2) MISR collocated and averaged to MODIS; (3) MODIS collocated and averaged to CERES; (4) ASTER or MISR collocated to CERES. As Table 1 shows, each offers particular advantages and handling requirements.

Radiometric intercomparisons can also be performed among instruments on different satellites, particularly EOS AM to EOS PM and EOS to TRMM. Except for CERES-

to-MODIS, there are no current operational plans for long-term Project-wide comparisons. We need to identify parties to organize such intercomparisons.

Chris Justice reviewed EOS calibration and baseline sites. These include: 3 EOS TOPO-DEM test sites handled through the land processes DAAC, 1 EOS site for ASTER (aircraft, DEM, ground data) plus ASTER's list of 40 to 60 sites; MODIS land-cover test sites/Landsat Pathfinder (40 to 60 sites); and EOS calibration-related sites (White Sands site and others TBD). Barker noted that CEOS/Guenther have distributed a form, the results of which are being inserted into a Science Processing Support Office (SPSO) Test Site and Field Experiment Data Base.

ASTER to MODIS	<p style="text-align: center;">Table 1.</p> <ul style="list-style-type: none"> <li>• Must maintain information on solar illumination to time of observation with respect to seasons</li> <li>• May want to use cloud mask to facilitate intercomparisons</li> <li>• Some care must be taken with respect to spectral coverage</li> </ul>
MISR to MODIS	<ul style="list-style-type: none"> <li>• Simultaneous collocated radiances, but not all at same direction</li> <li>• Could be avoided by choosing comparison locations</li> </ul>
MODIS to CERES	<ul style="list-style-type: none"> <li>• Gives simultaneous collocated radiances, sometimes in same direction</li> <li>• Expected to be part of the operational processing</li> <li>• Spectral sampling differences make this a multivariable problem</li> </ul>
ASTER or MISR to CERES	<ul style="list-style-type: none"> <li>• Spatial filling and spectral sampling make direct intercomparisons difficult</li> </ul>
EOS AM and EOS PM	<ul style="list-style-type: none"> <li>• AM and PM swaths will cross at fixed latitude.</li> <li>• Can get matches of both observations at nadir, and both at high off-nadir angles (different solar azimuths).</li> </ul>
EOS AM and TRMM	<ul style="list-style-type: none"> <li>• TRMM will have a 3-month precession period</li> <li>• Can have intercomparison region drift over ranges of latitude.</li> </ul>

Sellers provided a summary of near-term validation experiments. Data from these campaigns will be used to check out our models and algorithms, and perhaps to put EOSDIS "through its paces."

Barker discussed MODIS quick-look requirements to support monitoring and troubleshooting, as well as support of field campaigns. Barker stated a requirement for 5% of MODIS data with a 6-hour availability at the

Distributed Active Archive Center (DAAC), allowing 2 additional hours for product generation. He felt that this should be a routine function of EDOS/EOSDIS. Barker will draft a letter for the EOS Senior Project Scientist to deliver to EDOS.

### ALGORITHM DEVELOPMENT

The AM Project is eager to obtain information necessary to develop preliminary schedule and costs for the proposed standard data products. An algorithm development schedule was presented at the meeting. Early activities include the ATBDs and peer reviews, along with deliveries of the beta toolkit and standard product software. A process for algorithm development was described, and includes ATBD development and publication, code-writing, and operational integration.

Steve Wharton, EOSDIS Project Scientist, discussed responsibilities, steps, and schedule associated with algorithm development/implementation. Barkstrom felt that, for CERES, the requirement for one version per year is too often, given certain CERES-specific activities. Ghassem Asrar agreed that CERES may be a special case due to its special experience with ERBE, and that other instruments may not have had the benefit of such experience.

H.K. Ramapriyan reviewed the status of the PGS Toolkit, the purpose of which is to isolate algorithms from the PGS architecture, provide the Science Computing Facility (SCF) an environment that emulates the PGS, minimize redundancy, and increase portability. Hughes delivered the final baseline requirements for the PGS Toolkit October 29. There are three classes of tools: system mandatory (resource access, file I/O); science mandatory (spacecraft ephemeris and attitude); and science optional. Data Processing Focus Team (DPFT) approved standards and guidelines can be obtained through anonymous ftp from [ulabibm.gsfc.nasa.gov](ftp://ulabibm.gsfc.nasa.gov).

### *Simulated Datasets*

Skip Reber reviewed UARS experience with simulated data, noting that aggressive instrument simulations are key. The data should reflect several days of operations, simulating the raw telemetry stream including engineering data. Noise and data gaps are used to test the system. Simulations should model instrument and spacecraft quirks such as thermal snaps, should be as realistic as

possible, and would require several iterations similar to data processing software deliveries. Barkstrom suggested a simulation across multiple instruments perhaps one year before launch. Mark Elkington noted the importance of also simulating ancillary and auxiliary data streams. Wayne Esaias mentioned that the Sea-viewing Wide Field-of-View Sensor (SeaWiFS) project was doing this routinely and was finding it extremely beneficial. Paul Hwang and Sellers suggested the incorporation of a consensus model atmosphere and consensus model surface. Reber suggested that the interdisciplinary investigators be involved for the model aspect, as with UARS. Ardanuy noted that the complexity of EOS AM simulation is greater than UARS and that fractals could serve to project self-consistent fields to higher resolutions.

Sellers put forward a plan to create a small representative group to address simulations. There was a discussion of allocation of resources to support the development of a model Earth. Sellers proposed that Reber chair the simulation working group. Reber accepted. Several specific simulation representatives were assigned: Hank Sneider for CERES, Steve Unger for MODIS, and MOPITT, MISR, ASTER to report on representatives in the future.

### *Budget Planning and Reporting*

Ed Chang reviewed progress toward getting consensus on the science agreements, to be distributed to PI/TM/TLs by mid January. The science agreements will cover science, software, and instrument operations (including simulated instrument data). Ann Kahle noted that the topic of "research" had been left out *again*. Chang said that the process includes quarterly reviews and annual reviews, with peer reviews in 1994 and 1999. The consensus opinion was that the peer-review schedule was not frequent enough.

### *Algorithm Science Review*

Science peer review of algorithms and products will be an important EOS element. Each ATBD will be used to understand and, with test results, judge the merits of the algorithm. The ATBD will also serve as a reference to be attached to each data product. The reviews are to be conducted in May 1994. King reviewed the desired content and format of ATBDs. The ATBD is to be a description of the algorithm and data product characteristics, to be completed about 4.5 years before launch.

ATBDs are to be written for each algorithm, though closely related algorithms may be combined. Barkstrom commented that the CERES approach is different—a single seamless document.

Table 2.  
ATBD Reviews

Week 1	5/9/94	<ul style="list-style-type: none"> <li>• MODIS</li> <li>• CERES</li> <li>• MISR</li> </ul>
Week 2	5/16/94	<ul style="list-style-type: none"> <li>• ASTER</li> <li>• LIS</li> <li>• SeaWinds</li> <li>• MOPITT</li> </ul>

He also recommended that the ATBDs be published through EOSDIS as a literature reference. Martha Maiden noted that the ATBD is perfectly suited for acting as guide documentation for algorithm metadata. King recalled that the atmosphere (published) and land (in-press) discipline groups of MODIS have published the theoretical description of MODIS algorithms, and Asrar suggested that journal articles cite the ATBD as a source for additional information, to be archived through EOSDIS.

*Metadocumentation*

Ed Masuoka reviewed progress on product metadocumentation and presented product dependencies within MODIS, a program that enables automatic decommutation of the Science Processing Support Office (SPSO) database to extract product interdependencies, and a chart showing the interdependencies between MODIS and other instruments.

Chang agreed to produce charts for all instruments consistently, with Dan Wenkert offering to contribute as well. Jim Stobie cautioned that we should not forget about the interdisciplinary investigators. For example, the DAO might process MODIS information to provide atmospheric temperature profiles to MOPITT. Sellers requested that Chang and representatives from EOSDIS head this up, with Chang also adding his desire to get the SPSO involved. Chang will provide an integrated first cut in time for the ATBD reviews.

*Data Quality Information*

Barkstrom presented the “CERES/Barkstrom” view that, for every run, a quality control graphic will be created with the AI/expert system equivalent of a green light. This

will be created to go to the reviewers and to be put into the metadata as a part of the product. Reber commented that every group has thought about how they want to do quality assessment, and how to inform the users—we would like to get them together to develop common approaches, so that there are not as many methods as there are data products. Ted Meyer noted that the DPFT has an action to report back on quality assurance.

*Formulation of Consensus Algorithm Development and Review Process*

Sellers reviewed plans for ATBD delivery and peer review. It was decided to slip ATBD deliveries to the PSO until the end of February, but earlier if possible.

Valuable conversation took place in response to Piers Sellers’ presenting a schedule for software deliveries. Some discussion ensued concerning the advisability and necessity of running beta software at the DAACs in the T-36 month timeframe. The discussion demonstrated the differences in approach and attitudes of the participants. There was no consensus on the proper approach, but representative positions included the criticality of running beta software to get resource estimates and check interfaces, balanced by a perception that beta software should not be delivered because of DAAC environment instability. There were statements from several participants to the effect that aggressively running beta software in the timeframe under discussion would help reduce risks in the long run.

To help address these issues, Sellers suggested that each team write a statement of anticipated gain from the software deliveries, beginning with the beta versions. Meyers’ suggested that the ESDIS Project first delineate the purpose of each version, and that the teams specify dates. In response, Sellers asked that Wharton provide a preliminary schedule and definition of deliveries for each version, to be included in a letter to the science teams. The schedule should include “T-*nn*” dates, and in the cases of CERES and LIS, with respect to an earlier TRMM launch, actual calendar dates.

The next SWAMP meeting will be held at the upcoming IWG meeting in San Antonio, Texas, to review action item status and assess progress on critical issues, particularly algorithm development and implementation plans. ■



## ASTER Science Team

—Yasushi Yamaguchi (yasushi@gsjrstn.gsj.go.jp),  
Geological Survey of Japan.  
Andrew Morrison (andy@lithos.jpl.nasa.gov), JPL.

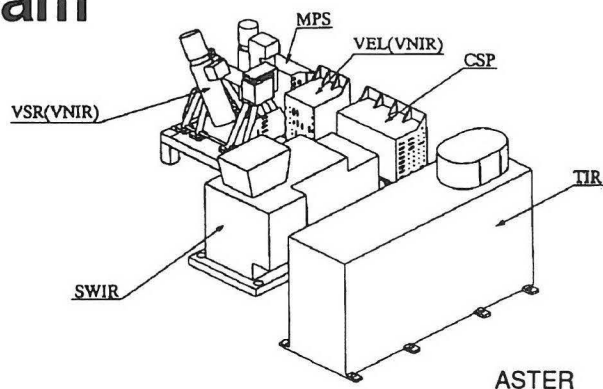

The sixth meeting of the ASTER Science Team was held November 9-12, 1993, in Tokyo, Japan. There were approximately 80 participants including representatives of the Japanese and U.S. ASTER Science Team, EOS Program at NASA Headquarters, JPL ASTER Science Project, EOS Project at GSFC, EROS Data Center, MODIS Science Team, Earth Resources Satellite Data Analysis Center (ERSDAC), Japan Resources Observation Systems Organization (JAROS), the instrument developers, the Japanese secretariats from the Meteorological Research Institute (MRI), interpreters, and observers.

The meeting began with a half-day plenary session that was followed by 2.5 days of Working Group meetings. It closed with a plenary session to summarize the results of the Working Group sessions.

Participants were welcomed to the meeting by Masao Ohmichi, the Director of Space Industry Division, Ministry of International Trade and Industry (MITI). Yoshinori Miyazaki of the Geological Survey of Japan (GSJ) and Matt Schwaller of GSFC reported on the current status of the ASTER MOU, PIP, and ICWG. Hiroji Tsu, ASTER Science Team Leader, then laid out issues to be addressed in the meeting. He emphasized three points: Japan-U.S. cooperation in algorithm development for Level-1 data products, the global mapping success criteria and prioritization, and algorithm development for the higher level data products.

Hiroyuki Fujisada of the Electrotechnical Laboratory (ETL) and Masahiko Kudoh of JAROS provided the update on the ASTER instrument project status. ASTER instrument development is now in the Engineering Model (EM) fabrication phase. Detailed interface designs are being worked out between MMC and the Japanese contractors. The test kinematic mounts and test cold plates were delivered from NASA to Japan recently. Scott Lambros of GSFC reported on the status of the EOS AM Project. He listed the issues of interest such as the configuration of the solid-state recorder and a potential disturbance problem by the coolers.

Gary Geller of JPL reported on the ASTER End-to-End Data System concept. Isao Sato of GSJ provided an overview of the User Interface Requirements Document, which is being prepared by the Japanese ASTER Ground Data System (GDS) Committee and the ASTER GDS Project in ERSDAC. The purpose of the User Interface Requirements Document is to identify the functional requirements of the Science Team members to the ASTER GDS.

### Operations and Mission Planning Working Group (Leaders: Hiroji Tsu/David Nichols)

There was considerable discussion in this meeting about the draft User Requirements Document for Mission Operations and the update of the operations scenario analysis. The ASTER GDS concept for ICC, IMS, and IST was presented by

the ASTER GDS Project in ERSDAC. The areas identified for follow-on investigations include "representative" worst-case orbit (divided observations), use of cloud prediction for instrument schedule optimization, minimum consecutive data acquisition time required for intertelescope band-to-band registration, refinement of DAR evaluation and conflict resolution concepts, establishment of global data set acquisition and science priorities, and refinement of a scenario generation tool. It was agreed to hold an *ad hoc* Working Group meeting in March 1994 in Tsukuba, Japan.

### **Level-1 Processing Working Group (Leaders: Hiroshi Watanabe/Gary Geller)**

Hiroyuki Fujisada presented a detailed concept of Level-1 data processing. The relationship between Japan and U.S. regarding generation of the Level-1 data product was discussed. It was agreed that technical discussions between the Japanese and U.S. ASTER Team members will be held more frequently. An *ad hoc* Level-1 working group meeting will be held in March 1994 in Tsukuba, Japan.

### **Higher Level Data Products Working Group (Leaders: Yasushi Yamaguchi/Anne Kahle)**

The Working Group name was changed from "Data Product and Validation Working Group" to "Higher Level Data Products Working Group." The members agreed that: 1) for the standard data products, all algorithms produced in both countries will be identical, but the source code can be different; and 2) there will be one unified data products list and one Science Data Product Specification (SDPS) document. It was proposed to produce all Level-1A subsampled browse products and also similar browse products for all Level-2 standard products, as they are generated.

### **Calibration Working Group (Leaders: Fumihiro Sakuma/Philip Slater)**

The major issues in this meeting were follow-up discussions of issues from the Calibration Peer Review held in March. Outlines of the radiometric correction algorithms were reported by the Japanese instrument vendors. Philip Slater and Yasushi Yamaguchi presented the update of the vicarious calibration plan, and Fumihiro Sakuma reviewed the current round-robin calibration plan for the

EOS AM-1 instruments. Hiromi Ono of JAROS showed the calibration results of JERS-1 OPS.

### **Geometric Working Group (Leaders: Hiroshi Watanabe/Hugh Kieffer)**

The geometry section of the End-to-End Data System Concept Document prepared by Gary Geller was reviewed. The role of the geometric working group was discussed, but most of the items listed by Hugh Kieffer were postponed to the next meeting because of his absence.

### **Temperature-Emissivity Separation Working Group (Leaders: Shuichi Rokugawa/Alan Gillespie), Atmosphere and Atmospheric Correction Working Group (Leaders: Tsutomu Takashima/Frank Palluconi)**

These two working groups met jointly. Shuichi Rokugawa, Masao Moriyama, Jack Salisbury, Tsuneo Matsunaga, Zengming Wan, and Kurt Thome presented the atmospheric correction and temperature emissivity separation algorithms. The candidate atmosphere models for ASTER atmospheric correction were the new meteorological model being developed by the EOS scientists, NOAA NMC global model, local radiosonde data, and use of data from other sources such as MODIS, MISR, NOAA-K, L, M, etc. It was agreed to continue evaluation of these models and data sources in terms of simplicity, robustness, speed, reliability, etc.

### **Geology Working Group (Leaders: Yasushi Yamaguchi/Lawrence Rowan)**

Bryan Bailey presented the LPDAAC update. Jack Salisbury and Yasushi Yamaguchi reported on the update of spectral library development in U.S. and Japan, respectively. The members came to a consensus that the Working Group recommends decorrelation stretch for generation of the standard product of relative spectral reflectance (2A03). It was also agreed to prepare a global land surface priority map by compiling the priorities of the subdisciplines such as volcanic and seismic activities, paleoclimate studies, non-renewable resources distribution, etc.

### **Ecosystem and Land Surface Climatology Working Group (Leaders: Yoshifumi Yasuoka/Thomas Schmugge)**

The Working Group members introduced their recent research activities. This was followed by discussion of definitions, algorithms, ancillary data, and differences in Japanese and U.S. data products. Prioritization of global mapping and potential test sites for the ecosystem studies were also discussed. Study of this issue will be continued.

**Oceanography and Limnology Working Group (Leaders: Motoaki Kishino/Michael Abrams)**

Ocean color studies using ASTER data were identified as having marginal value because the VNIR bands were spectrally too broad and the SNR is insufficient. Aquatic plant distributions and bay/lake surface temperature were identified as potential oceanography and limnology targets. There was no ASTER global ocean temperature mapping requirement identified because of ASTER's narrow swath and long recurrence period. The effort to identify other potential oceanography/limnology users of ASTER data will be continued.

**Digital Elevation Model (DEM) Working Group (Leaders: Yoshinori Miyazaki/Roy Welch)**

The main issues discussed were the availability of Ground Control Points (GCP) libraries, Japan-U.S. collaboration on DEM generation, preparation for the algorithm science review, and a proposal for an ASTER DEM User manual. DEM is categorized as a standard data product in the U.S., while Japan is interested in generating the DEM products for East Asia on a routine basis. It is noted that the future Japan-U.S. collaboration for DEM generation is a key issue, and its detailed procedures and implementation urgently have to be defined in the near future.

**Airborne Sensor Working Group (Leaders: Shuichi Rokugawa/Simon Hook)**

Mike Abrams and Simon Hook briefly reviewed the results of the TIMS deployments in Kamchatka and Australia, respectively. They also reported on the status of NASA airborne sensors and the new data policy. Larry Rowan showed results from Iron Hill using TIMS data. Yoshiaki Kannari of JGI reported on the current performance and flight plans for the ASTER Airborne Simulator (AAS).

The next Joint ASTER Science Team meeting will be held the week of May 23, 1994, in Southern California, U.S.A.

EOS News — December 29, 1993

# SAC-C INSTRUMENT WORKSHOP

A workshop to discuss instruments for the joint U.S.-Argentina SAC-C mission was held by NASA and CONAE (Comision Nacional de Actividades Espaciales) in Buenos Aires on December 1-3. Recommendations of the working group gave highest priority to the following instruments: 1) Global Positioning System Receiver (GPS); 2) Magnetometer; and 3) Multispectral Medium Resolution Scanner (MMRS). NASA proposed a baseline GPS for precise orbit determination and will study the possibility of adding capabilities to perform atmospheric occultation experiments and/or an accelerometer to improve gravity modeling. Magnetometers proposed by the Jet Propulsion Laboratory and the Danish Oersted Satellite Project will be reviewed by NASA. CONAE agreed to consider modifying spectral channels in MMRS to make it more useful for coastal oceanography applications. All reports are due by March followed by a spacecraft accommodation assessment in April. Preliminary plans for the SAC-C satellite are for a sun-synchronous, afternoon-crossing polar orbit at an altitude of 500-600 km.

# First International MIMR Science Advisory Group Meeting

—Michael King (king@climate.gsfc.nasa.gov), EOS Senior Project Scientist, Goddard Space Flight Center.

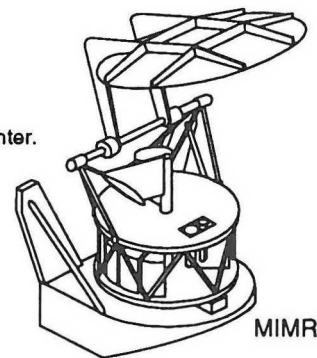

The first international meeting of the MIMR Science Advisory Group (SAG) was held at the European Space Research and Technology Centre (ESTEC), Noordwijk, Holland, November 16-18, 1993. ESTEC is the largest of the European Space Agency's facilities.

The opening day consisted largely of a plenary session in which Michael King gave an overview of NASA's EOS program, Chris Readings (Head, Earth Sciences Division, ESA) an overview of ESA's ERS-1, ERS-2, ENVISAT-1 and METOP-1 programs, and Graham Mason (EUMETSAT) an overview of EUMETSAT and its role in operational meteorological satellites (METOP-1 and its relation to NOAA's polar orbiting satellite program). Roy Spencer, U.S. Team Leader for MIMR, spoke on MIMR science objectives and challenges, representing the issues and concerns of greatest interest to the full NASA-supported MIMR Science Team. He was especially concerned with the following issues: (i) parameter cross-talk and the need to do simultaneous physical retrievals so that errors in one derived parameter are uncorrelated with other derived parameters (e.g., wind speed and total precipitable water), (ii) radiative transfer intercomparison needs so that a consistent set of radiative transfer programs are utilized both in simulations and in data processing, (iii) algorithm interfacing between the Europeans and the Americans for identification of ocean, land, atmosphere, and cryosphere parameters, (iv) grids for level-3 processing, (v) use of other sensors, such as AIRS, AMSU-A and MHS, to specify air temperature when retrieving oceanic water vapor, (vi) field experiments, and (vii) level-0 to level-1B processing issues, including radiometric calibration and Earth location.

The MIMR Instrument Manager (Yvonne Menard, ESA) then described the MIMR instrument, based on the latest

phase-B results, including the advantages of MIMR over SMMR (larger antenna, 90 GHz channel, conical scanning, better sampling, external calibration) and SSM/I (larger antenna, better sampling, lower frequency channels at 6.8 and 10.65 GHz, multi-horn system to provide better antenna performance). The SAG was asked to comment on preferred viewing angle for the conical scanning radiometer (55°, 50°, 45°), which had implications on (i) swath width, (ii) footprint size, and (iii) similarity to emissivity characterization and heritage of previous sensors (SSM/I). The SAG was also asked to comment on the acceptability of the 89 and 37 GHz footprints, to make a recommendation on the need to include temperature sounding channels on MIMR, and to articulate the scientific benefit of flying two MIMRs in orbit simultaneously (METOP-1 in the morning and PM-1 in the afternoon).

Each member of the SAG then gave a brief presentation on what their interests were in MIMR. Chris Mätzler (University of Bern) pointed out that there are numerous ground sources of microwave radiation at the lower MIMR frequencies (6.8 and 10.65 GHz) from sources such as TVs and other communication systems. This might lead to "speckle" on the ground that the satellite sensor would see. Peter Schlüssel (University of Hamburg) suggested the ability to retrieve not only total precipitable water but also boundary layer water vapor. He found that the boundary layer contributes only 10% of the total precipitable water vapor in the tropics (ITCZ region) and Antarctic and Antarctic polar vortex, but up to 40% elsewhere.

The remainder of the SAG meeting was largely composed of four working subgroups in parallel sessions: Atmosphere, Ocean, Land, and Cryosphere. Each of these



subgroups met separately and then came together for a plenary report on recommendations as follows:

### *Atmosphere*

The top priority of MIMR for the Atmosphere Subgroup was the hydrologic cycle (including rainfall, precipitable water, cloud liquid water path, and evaporation, which in turn depends on wind speed, sea surface temperature, and water vapor density). This subgroup made a distinction between Project Products (EOSDIS) and PI Products (research products processed at an SCF), and generally felt that fewer “official” at-launch products were preferable to many, highly visible and controlled, data products. They examined the data products list and accuracies that Ghassem Asrar and Michael King had generated as a result of the IWG Meeting and subsequent communication with Team Leaders, and made suggestions on some of the accuracies contained in these tables. They felt the need to map instrument characteristics to science return and accuracies (Science Plan). They emphasized that having different spatial resolutions at different frequencies was *not* a problem. With regard to incidence angle, the Atmosphere Subgroup, as well as all other subgroups, recommended a 53° inclination angle for MIMR on both METOP-1 and EOS PM-1. The Atmosphere Subgroup recommended direct broadcast for use to support field campaigns. They *did not* recommend adding temperature sounding channels to MIMR. This subgroup reiterated that the SAG should seek to develop unified algorithms (4-parameter simultaneous algorithm with no cross-talk, for example) between the U.S. and European investigators. They felt that there was a need for model intercomparisons (i.e., spectroscopy, scattering, radiative transfer), and a compelling need to characterize the dielectric constant of sea water and pure water at MIMR frequencies.

### *Ocean*

For the Ocean Subgroup, the mission objectives were separated into primary parameters (SST, surface wind speed, precipitable water vapor, and cloud liquid water path) and secondary parameters (latent heat flux, sensible heat flux, longwave radiative flux, momentum flux, and particle flux from biogenic and lithographic sources), the latter grouping of parameters hinging on a combination of the primary parameters. This subgroup also stated the scientific accuracy expected from MIMR observations (0.5 K for sea surface temperature, 1 m s<sup>-1</sup> for wind speed,

1 mm (total) and 0.5 mm (PBL) for water vapor, and the greater of 0.05 mm or 10% for cloud liquid water path). They noted the desirability of temperature sounding capability in the lower and middle troposphere, but did not insist that these measurements come from MIMR. They recommended a 53° inclination angle for MIMR, consistent with SSM/I. Again they recommended simultaneous retrieval to avoid cross-talk among parameters. Finally, they recommended two pre-launch experiments: (i) dielectric constant of sea water (at MIMR frequencies), and (ii) ocean emissivity measurements. The latter experiment is hard to design properly, and hence such an experiment may be of limited utility; thus necessitating modification of the emissivity parameters post-launch. Finally, they seemed very excited about the synergistic possibilities provided by flying MIMR with a temperature and water vapor sounder (AIRS/AMSU/MHS on EOS PM and IASI on METOP-1).

### *Land*

The Land Subgroup focused on using global microwave measurements for studies of the hydrologic cycle and climate processes, such as snow extent and properties (water content is difficult), surface temperature, biomass, soil moisture information, and surface fluxes (i.e., evapotranspiration). MIMR should have a major advantage over SSM/I for land process studies because of its smaller footprint size (a 5 km resolution is needed for snow applications in Alpine regions). This subgroup, like many before it, recommended getting temperature information from AIRS and AMSU and not adding temperature sounding channels to MIMR directly. For land purposes the spatial resolution is more important than swath width. Without exception, land products are appropriate post-launch products; the maturity is lacking for at-launch algorithm development. This subgroup recommended building and deploying a MIMR airborne simulator as soon as possible, and exploiting it in field campaigns to gain experience.

### *Cryosphere*

The Cryosphere Subgroup focused primarily on sea ice applications, including operational mapping, research for climate and GCM purposes, and studies of geophysical processes (both global and regional). Global coverage once per day is sufficient for cryosphere applications. For motion vector fields and edge detection, it is desirable to

have a spatial resolution of 5 km, though 15 km is adequate for global modeling purposes. This subgroup was insistent on timely data delivery and direct broadcast for icebreaker and other shipping interests. The Cryosphere Subgroup likewise specified the accuracies expected from MIMR data: (i) ice concentration (pack ice in winter; 6%), (ii) classification (first year, multi-year, open water/thin ice; 20%), (iii) edge (defined at a concentration of 10% according to the WMO; 5 km). For climate purposes, a long-term time series was invaluable, but a sampling of once per day was adequate. Preben Gudmandsen (Technical University of Denmark) commented that the energy flux from open water to the atmosphere in the Arctic polar region ranges up to  $500 \text{ Wm}^{-2}$  due to the large temperature inversions prevalent during the winter. This exceeds the summertime value. Among the relevant data products from MIMR, the Cryosphere Subgroup highlighted: (i) global sea ice concentration, (ii) ice edge detection, (iii) area of ice canopy (extent), (iv) motion fields, (v) surface ice temperature (research product), (vi) surface conditions (research product with several parameters, such as snow depth, melt ponds, etc.). This subgroup recommended forming a team for algorithm development (Joey Comiso, Don Cavalieri, Preben Gudmandsen, Rene Ramseier), led by the SAG.

It is expected that a unified international MIMR Science Team will emerge from this meeting. Each subgroup was charged with preparing text for a MIMR booklet describing the science rationale and promise of the MIMR experiment on two spacecraft (METOP-1 and PM-1). The first draft of this report is to be completed by the end of February for circulation amongst the members of the SAG. Chris Readings asked whether there were any gaps in the SAG that would require that additional members be appointed. Robert Adler was proposed as a new member but his appointment has not yet been confirmed by ESA. Any new U.S. members must be from among the seven NASA-approved MIMR Science Team members (four of whom are already SAG members).

In conclusion, the full Science Advisory Group made the following recommendations:

- MIMR should be a conical scanning microwave radiometer with a  $53^\circ$  incidence angle at the surface for both METOP-1 and PM-1;
- The 89 and 37 GHz footprint sizes are fine as currently designed;

- Direct broadcast is desirable, but not essential for scientific research; and
- No temperature sounding channels should be added to MIMR.

The Cryosphere Subgroup will be led by Joey Comiso (NASA Goddard Space Flight Center) and the Atmosphere Subgroup by Tom Wilheit (Texas A&M University), both NASA-supported scientists, while the Land Subgroup will be led by Chris Mätzler and the Ocean Subgroup by Peter Schlüssel, both ESA-supported scientists. This should help establish a balanced working relationship between ESA and NASA members of the MIMR Science Advisory Group. ■

EOS News Educational Supplement - December 29, 1993

### USRA/GSFC GRADUATE STUDENT SUMMER PROGRAM

The Universities Space Research Association and NASA Goddard Space Flight Center Earth Sciences Directorate are offering a limited number of graduate student research opportunities for a program scheduled June 13 to August 19, 1994. The program is designed to spur interest in interdisciplinary studies in Earth System Science, and will enable selected students to choose from a pool of research projects and mentors at GSFC. The first week will include a public lecture series entitled *Observing the Earth from Space: Observations, Modelling and Predictions of the Earth Science System and Global Change*. The program is open to students enrolled or accepted in an accredited graduate program in physical sciences, biological sciences, mathematics, computer science or engineering. Stipends pay \$8.50/hour up to 40 hours/week for the 10-week period. Expenses for domestic travel to, and housing near, Greenbelt, MD can be covered by USRA. Applications must be received by February 14, 1994. For information and application materials contact Paula Webber, Program Coordinator USRA/GSSP, Mail Code 610.3, NASA/Goddard Space Flight Center, Greenbelt, MD 20771, phone (301) 552-8772, e-mail: paula@gvsp.usra.edu.

# Total Solar Irradiance Monitoring

Report of the Atmospheres Panel to the Payload Panel  
November 1993

—D. L. Hartmann (dennis@atmos.washington.edu), Panel Chairman.  
B.R. Barkstrom, D. Crommelynck, P. Foukal, J.E. Hansen, J. Lean,  
R.B. Lee III, M.R. Schoeberl, R.C. Willson

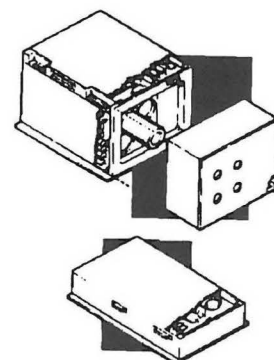

ACRIM

## 1.0 Executive Summary

1.1 *Variations of total solar irradiance that have been directly observed to date are smaller than the anthropogenic climate forcing and are too small to have a measurable effect on climate. Total solar irradiance is, nonetheless, a critical control of climate and needs to be monitored in order to assess observed and predicted climate changes.*

Changes of total solar irradiance (TSI) are suspected of being one of the causes of past global climate changes on decade-to-century time scales, but proof of this is lacking because there is no long-term record of TSI with sufficient precision. Current active cavity radiometer designs are able to measure the total solar irradiance with an absolute accuracy of about  $\pm 0.35\%$ . The relative precision of existing measurements is believed to be much better, perhaps about  $\pm 0.01\%$ , and future measurements may have relative precision as good as  $\pm 50$  ppm. Simultaneous measurements from several instruments show consistent variations of TSI during the 11-year solar cycle with an amplitude of about 0.1%. This amount of solar irradiance variability is too small to cause a practically significant or mea-

surable variation in global surface temperature. The equilibrium response to steady forcing of this magnitude would be 0.1 to 0.2 K, and the transient response to periodic 11-year forcing would be less than half of the equilibrium response to steady forcing. The magnitude of the anthropogenic greenhouse gas climate forcing calculated over the period 1750 to 2000 is about  $2 \text{ Wm}^{-2}$ , or about eight times the magnitude of the climate forcing associated with the 11-year solar cycle. The anthropogenic greenhouse gas forcing is expected to double again in the next 50 to 75 years (Shine, *et al.*, 1990). Solar irradiance changes during the next few decades are unlikely to cause a climate forcing as large as that from anthropogenic greenhouse gases, if the latter continue to increase rapidly. The net anthropogenic climate forcing may be less than that associated with greenhouse gases, however, since evidence suggests that climate forcings associated with anthropogenic changes in aerosols and clouds may have offset as much as half of the anthropogenic greenhouse enhancement that has occurred up to the present time. Whatever the anthropogenic climate forcing, without measurements of the natural climate forcing from solar irradiance changes, it will be difficult

to assess the implications of observed climate changes.

1.2 *An effort to measure variations in total solar irradiance on time scales longer than an 11-year solar cycle should be maintained.*

Since the 11-year cycle is the largest regular variation in solar activity, and its effect on total solar irradiance is small, it is tempting to conclude that TSI variability is not of major concern for climate variations over the next 100 years. The primary worry with this conclusion from the perspective of global climate change prediction is that TSI variability on longer time scales than the 11-year cycle might be larger in magnitude and would cause a significant climate response that would affect the interpretation of observed temperature trends and the strategies that might be developed to avert or mitigate the consequences of a human-induced climate change. Our knowledge of TSI variability and its relationship with solar activity is, after all, based on measurements over only one complete solar cycle. Even if TSI variability on this time scale is small, if it is not measured, an uncertainty will remain about its potential influence which might slow the development of ef-

fective policies regarding global climate change.

*1.3 The best strategy for measuring long-term trends in total solar irradiance is to continue the sequence of overlapping measurements with instruments specifically designed to measure total solar irradiance with absolute calibration.*

Because the precision, but not the accuracy, of TSI measurements is sufficient for long-term monitoring, detection of long-term trends requires substantial overlap between succeeding instrument packages so that they can be calibrated against each other and provide a record of TSI deviations. To retain this precision against instrumental degradation, each package requires multiple detectors. With the currently planned schedule for launches of active cavity radiometer (ACR) instruments, a gap in the record will likely occur between the end of UARS/ACRIM measurements and the SOHO/VIRGO measurements sometime in the 1994-6 interval and again between SOHO/VIRGO and the planned launch of the ACRIM on EOS/CHEM in about 2002.

*1.4 Indices of solar activity are well correlated with total solar irradiance over the 11-year solar cycle, but the precision of these indices and their statistical relationships with TSI are probably inadequate for long-term trend detection.*

Since some quantitative measures of solar activity that can be accurately measured from the ground are well-correlated with TSI, it is reasonable to ask whether these data might be used to bridge gaps between more direct measurements of solar energy

output variations. This strategy will need to be employed if the required overlap between direct measurements cannot be achieved, but it is questionable whether the required high level of precision can be maintained in this way. On a fundamental level, the physical relationships between solar activity indices and TSI are not understood, so that the relationships are purely statistical in nature. Also, it is unclear whether the relationships between solar activity indices and TSI that are obtained from observing the 11-year cycle are the same as those that would apply for longer-term solar activity and solar irradiance variability, which may result from different physical processes within the sun. On a more practical level, the precision inherent in the statistical relationships may be less than the precision required to measure the very small trends that are expected. It is also unlikely that the solar activity indices themselves possess the high precision and stability required for TSI trend detection (e.g.  $\pm 0.01\%$  or less over the gap interval).

## 2.0 Total Solar Irradiance: A Fundamental Control on Climate

The total solar irradiance (TSI) or solar constant is the total radiative energy flux density reaching the mean position of Earth from the sun. It is estimated to be  $1367 \pm 2 \text{ Wm}^{-2}$ . The total solar irradiance is by far the dominant source of heat for driving the energy and hydrologic cycles of Earth's climate system. A 2% change in solar constant gives a thermal forcing for the climate system that is about equivalent to a doubling of atmospheric carbon dioxide.

$$\frac{TSI}{4}(1 - \text{Albedo}) \times 0.02 \approx 4.8 \text{ Wm}^{-2}$$

Direct observations of total solar irradiance are limited to only a little over one solar cycle, during which the solar energy output variations were measured to be about 0.1%, which is too small to produce a measurable temperature change. Indices of solar activity show variations on longer time scales of 88 years or so, which are on the same time scale as the 100-year horizon for global greenhouse gas warming. If the total irradiance changes on these time scales are larger than those on the 11-year sunspot cycle time scale, then significant surface temperature changes could be attributed to total solar irradiance variations. Larger solar variations on longer time scales are suggested by empirical studies (Friis-Christensen and Lassen, 1991, Hoyt and Schatten, 1993). These potentially larger solar-forced climate changes might affect the detection of global climate changes caused by human actions, the assessment of future climate trends, and the policies we may develop to mitigate or adapt to them.

## 3.0 Direct Observations of Solar Constant Variability

### 3.1 Radiometers for TSI Monitoring

Currently, instruments for measuring the total energy output of the sun consist of unfiltered thermal detectors with both sun-viewing and reference cavities and electrical heat substitution to maintain constant instrument response. (We can call this an active cavity radiometer, or ACR for short). Such technology offers an apparent absolute accuracy of about  $\pm 0.35\%$ , but with substantially better precision of about  $\pm 50$  ppm (Willson, 1993, Crommelynck, 1993). Current designs such as ACRIM have three instruments in one package. The first



instrument views the sun continuously, while the other two are exposed only infrequently and are used to calibrate the first, which degrades slowly in response to its exposure to solar ultraviolet radiation.

### 3.2 Available Measurements

ACR instruments (or related designs such as the Hickey-Freidan radiometer on Nimbus-7) have been flown on a number of satellite missions. The longest continuous record is the 14-year record of the Nimbus-7 ERB, which began in late 1978 and ended

in early 1993. Overlapping this record are the Solar Maximum Mission (1980-1989) and the Earth Radiation Budget Experiment (1984-present) TSI measurements. An ACR is currently operating on the UARS satellite. The measurements from these instruments and a timetable of planned missions are indicated in Figure 1. The mean values of the solar constants inferred differ by  $7 \text{ Wm}^{-2}$  or about 0.5%. They each indicate a very similar magnitude for the variation of total solar irradiance over solar cycle of about 0.1%, however, so that, if the offsets are removed, the remaining differ-

ences are at about the 20 ppm level. This comparison indicates that the relative precision of measurement is much greater than the absolute accuracy. The primary constraint on absolute accuracy for current ACR instruments seems to be knowledge of the aperture area, and thermal perturbations by the field-of-view limiter (e.g., Crommelynck, 1989).

These intercomparisons suggest that long-term trend measurement with a relative accuracy considerably better than 0.1% could be achieved with a series of ACR instruments, if the flights

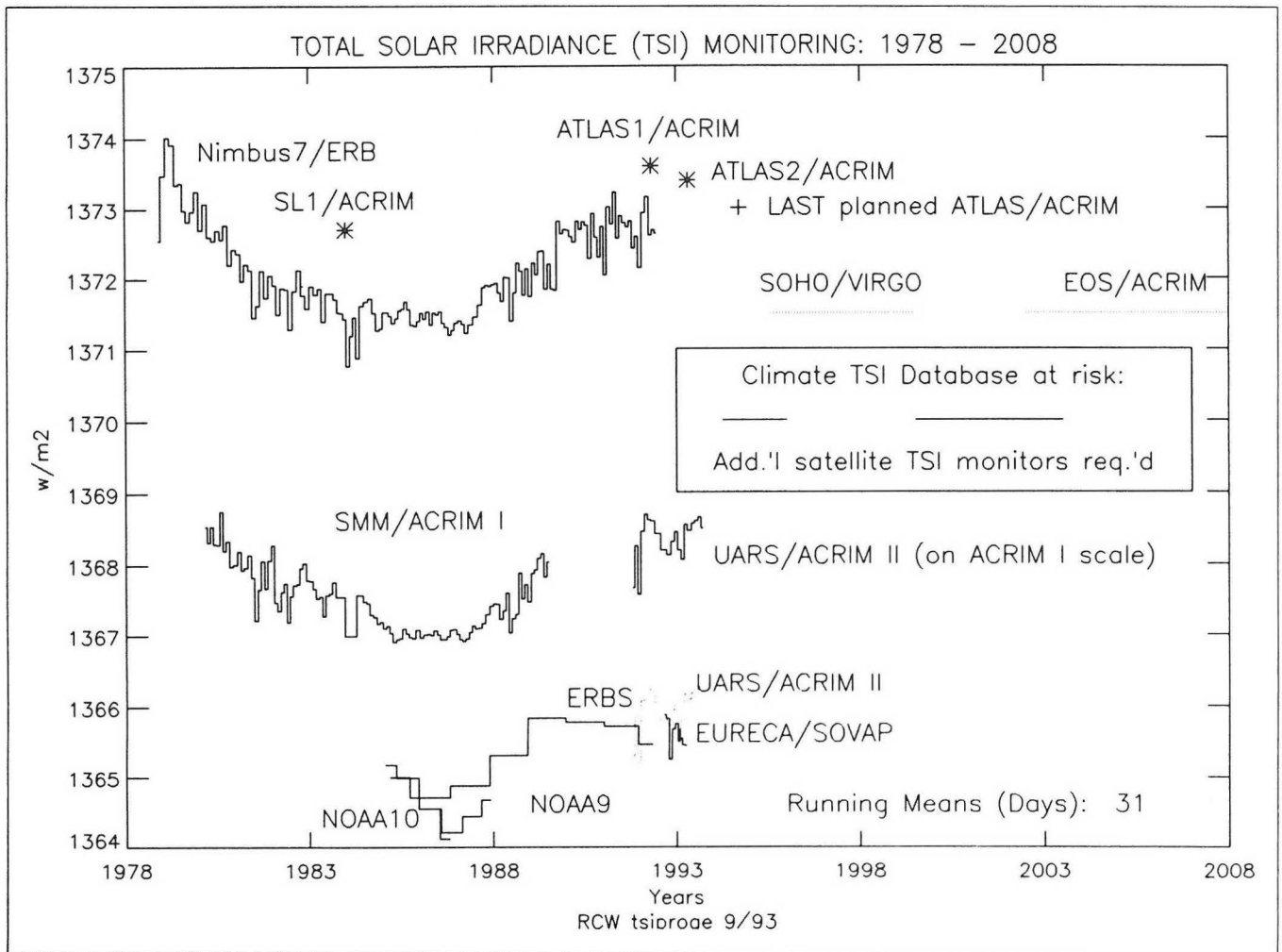

Figure 1. Measured total solar irradiance from 1978 through 2009 showing 31-day running-mean measurements taken from orbit and planned future mission launch dates. (Willson, 1993).

of the instruments overlap sufficiently in time to allow the biases between instruments to be measured. By adjusting the data to remove the bias differences, a long time series of TSI variations with an unknown but unchanging bias can be established. This "overlap strategy" has been proposed as one means of measuring solar constant trends that may exist at time scales longer than one solar cycle, beginning with the launch of the Nimbus-7 satellite in 1978.

### 3.3 Future Measurements and the Overlap Strategy

The strategy for long-term measurement of total solar irradiance requires overlap between succeeding ACR instruments, so that the biases between instruments can be accounted for, thereby producing an estimate of long-term deviations in TSI that is independent of the uncertainty in absolute accuracy. As can be seen in Figure 1, it is likely that the string of overlapping ACR measurements begun with Nimbus-7 ERB will be broken by gaps between the UARS/ACRIM and SOHO/VIRGO instruments in 1994-6 and again between SOHO/VIRGO and the planned EOS CHEM in 2002. Without overlap between past and future instruments, a record of long-term solar irradiance variations cannot be built upon the record available from the current generation of instruments.

### 4.0 Empirical Relationships between Solar Activity Indices and Solar Constant

A number of studies have shown that indices of solar activity such as photometric sunspot index, 10.7 cm flux (Lee, *et al.*, 1993), He 1083 line width (Willson, 1993, Willson and Hudson,

1991), Mg c/w ratio (Pap and Fröhlich, 1988, Willson, 1993b), and others (Livingston, *et al.*, 1991, Livingston *et al.*, 1988) have been well correlated with total solar irradiance over the period during which TSI has been observed. These correlations have been used to develop empirical models that predict TSI based on one or more of these indices of solar activity. These empirical models can represent the variation of TSI over the last solar cycle, although they obscure some of the higher frequency variability and usually underestimate the TSI at the peak of solar activity. The typical goodness of fit of these regression models is about 0.03 to 0.05%, compared to an 11-year solar cycle signal of about 0.1%, and this is based on only one solar cycle.

Some of these empirical models have been used to extrapolate TSI variability into the past. For example, Foukal and Lean (1990) have used indices of sunspot dimming and facular brightening to estimate variations of TSI over the period 1875-1988. The variations were generally smaller than the observed variation of the last solar cycle of 0.1%. Analyses of the effect of observed or expected TSI variations on climate have indicated that they should be small compared to changes expected from anthropogenic or other natural forcings over the next century (Hansen and Lacis, 1990, Kelly and Wigley, 1992). The main uncertainty on the century time scale seems to be with possible variations on longer time scales associated with, for example, the 80-year Gleissberg cycle in sunspot abundance (Baliunas and Jastrow, 1990). Lean *et al.* (1992) have used the linear relationship between Ca II emission and TSI observed over the

last solar cycle to extrapolate a TSI value that would apply for the conditions of minimal activity that are believed to characterize the Maunder Minimum period from 1645 to 1715. They estimate a TSI for that period that was 0.24% less than the average over the most recent solar cycle, which would give an equilibrium surface temperature response of from 0.2 to 0.5°C. A solar constant change of this magnitude would give a climate response that would be of practical significance.

The question arises whether the empirical relations between solar activity indices and TSI that have been used to estimate the possible magnitude of past and future TSI changes can be used to bridge potential gaps in the record of direct measurements of TSI. This is a questionable strategy for several reasons. First, the relationships are primarily statistical and based on slightly more than one 11-year solar cycle. It is unclear whether the statistical relationships so far derived are based on sound physical relationships, and whether these statistical relationships would be the same for 11-year cyclic variability and for possible longer-term variations in solar energy output. Also, it is probably true that the regressions between TSI and solar activity indices are not precise enough to provide the great precision necessary to measure small trends over several decades. Finally, the stability and precision of the indices for solar activity may not be adequate for detection of the small trends expected. For example, Tapping (1993) estimates the current precision of 10.7 cm flux measurements to be 0.5% (Tapping and Charrois, 1993).

## 5.0 Future Developments in Solar Irradiance Measurements

Improvements such as cryogenic radiometers (Foukal *et al.*, 1991) or precision laser measurement of apertures (Fischer and Stock, 1992) offer the possibility to increase the absolute accuracy available from satellite instruments. For a similar aperture-size field-of-view limiter, errors are much less in cryogenic radiometers, so more accurate knowledge of aperture area would be more fruitful than for uncooled radiometers, for which uncertainties associated with field-of-view limiter temperature and aperture area are of the same order. Such improvements would be of value, but would not help to connect past measurements with future ones, if a gap occurs in the measurement record before these improved instruments can be placed in service. Moreover, the added complexity and limited life of cryogenic radiometers would make the long-term continuous monitoring required more difficult and expensive.

### REFERENCE

Baliunas, S. and Jastrow, R., 1990: Evidence for long-term brightness changes of solar-type stars. *Nature*, **348**, 520-522.

Crommelynck, D., 1989: The solar constant: Status of our knowledge. *Adv. Space Res.*, **9**, 51-61.

Crommelynck, D., 1993: Status of our knowledge of the "solar constant" after the Atlas 1 & 2 and the Eureka missions. Royal Meteorological Institute of Belgium.

Fischer, J. and Stock, M., 1992: A non-contact measurement of radiometric apertures with an optical microtopography sensor. *Meas. Sci. Technol.*, **3**, 693-698.

Foukal, P. and Lean, J., 1990: An empirical model of total solar irradiance variations between 1884 and 1988. *Science*, **247**, 556-558.

Foukal, P.V., Hoyt, D.C., and Miller, P.J., 1991: Cryogenic radiometers for remote sensing and pyrheliometry. *Metrologia*, **28**, 225-259.

Friis-Christensen, E. and Lassen, K., 1991: Length of the solar cycle: an indicator of solar activity closely associated with climate. *Science*, **254**, 698-700.

Hansen, J.E. and Lacis, A.A., 1990: Sun and dust versus greenhouse gases: an assessment of their relative roles in global climate change. *Nature*, **346**, 713-719.

Hoyt, D.C. and Schatten, K.H., 1993: A discussion of plausible solar irradiance variations. *J. Geophys. Res.* (in press).

Kelly, P.M. and Wigley, T.M.L., 1992: Solar cycle length, greenhouse forcing and global climate. *Nature*, **360**, 328-330.

Lean, J., Hurlburt, E.O., Skumanich, A., and White, O., 1992: Estimating the sun's radiative output during the Maunder minimum. *J. Geophys. Res.*, **19**, 1591-1594.

Lee, R.B.I., Gibson, M.A., Wilson, R.S., and Thomas, S., 1993: Total solar irradiance variability during sunspot cycle 22. preprint.

Livingston, W., Donnelly, R.F., Grigoryev, V., Lemidov, M.L., Lean, J., Steffen, M., White, O.R., and Willson, R.L., 1991: Sun-as-a-star spectrum variability. *Solar Interior and Atmosphere*. A.N. Cox, W.C. Livingston, and M.S. Mathews, Eds., University of Arizona Press, 1109-1160.

Livingston, W.C., Wallace, L., and White, O.R., 1988: Spectrum line intensity as a surrogate for solar irradiance variations. *Science*, **240**, 1765-1767.

Pap, J. and Fröhlich, C., 1988: Correlation of solar irradiance variability with evolution of activity. *Adv. Space Res.*, **8**, 31-34.

Shine, K.P., Derwent, R.G., Wuebbles, D.J., and Morcrette J.J., 1990: Radiative Forcing of Climate. *Climate Change: The IPCC Scientific Assessment*. J.T. Houghton, G.J. Jenkins, and J.J. Ephraums, Eds., Cambridge University Press, 41-68.

Tapping, K., 1993: Personal communication.

Tapping, K. and D.P. Charrois, 1993: Limits to the accuracy of the 10.7cm flux, *Solar Physics* (in press).

Willson, R.C., 1993a: *Solar Irradiance*. preprint, JPL.

Willson, R.C., 1993b: *Solar monitoring has a past and present: Does it have a future?*, preprint.

Willson, R.C. and Hudson, H.S., 1991: The sun's luminosity over a complete solar cycle. *Nature*, **351**, 42-44. ■

EOS News - December 29, 1993

## NOAA GLOBAL CHANGE POSTDOCTORAL PROGRAM

The National Oceanic and Atmospheric Administration Climate and Global Change Program is soliciting applications from postdoctoral candidates and letters of intent from host scientists. The University Corporation for Atmospheric Research (UCAR) manages the program on behalf of NOAA for the benefit of the university community and government laboratories. The steering committee, which selects the fellows and assists in coordinating appointments with agencies and institutions, is interested in supporting research on climate variations with time scales of seasons to centuries. The program offers postdoctoral scientists up to a 2-year visiting research appointment. Scientists interested in being a host and providing research facilities should send a short letter stating their interest and describing background preferences for a postdoctoral fellow. The review committee will match candidates and hosts. Application materials must be submitted by March 1, 1994. For further information, contact the UCAR Office of Programs at (303) 497-8649 or send e-mail to B.APPELHAUS/OMNET or [bappelha@ncar.ucar.edu](mailto:bappelha@ncar.ucar.edu).

# Data Assimilation for EOS: Impact of Satellite Water Vapor Data on Precipitation Estimates

—Richard B. Rood (rood@dao.gsfc.nasa.gov) and David V. Ledvina, Data Assimilation Office, Code 910.3  
 NASA/Goddard Space Flight Center, Greenbelt, MD 20771

Data assimilation is a powerful method for organizing and extending observations of the Earth system. In essence, spatially and temporally scattered observations are assimilated into a model of the system at regular time intervals. While it is possible to show from a theoretical point of view that the assimilation approach can provide the best estimate of the state of the system, for many Earth scientists the most important aspect of assimilation is the fact that the model provides internally consistent estimates of observed quantities and a whole suite of data-constrained esti-

mates of unobserved quantities. An example of the power of assimilation is the use of winds from a stratospheric assimilation, which are not observed, to simulate ozone transport and, by extension, to reduce the uncertainty in atmospheric chemistry assessments (e.g. Rood et al., 1993).

The Data Assimilation Office (DAO) at Goddard Space Flight Center is developing generalized data assimilation algorithms under the umbrella of the EOS Interdisciplinary Science investigations. Needs for assimilation within NASA demand algorithms

that use more data types, cover larger domains, and save more diagnostics than the products produced operationally by the weather centers. The approach of the DAO is defined within the broad constructs of Kalman filter analysis. Practically, however, the DAO is pursuing algorithm development by producing data sets and trying to address a broad range of Earth science problems with the data sets. Applications within Goddard focus on climate-scale atmospheric variability and atmospheric chemistry. If the EOS assimilation effort is to be successful, then the data

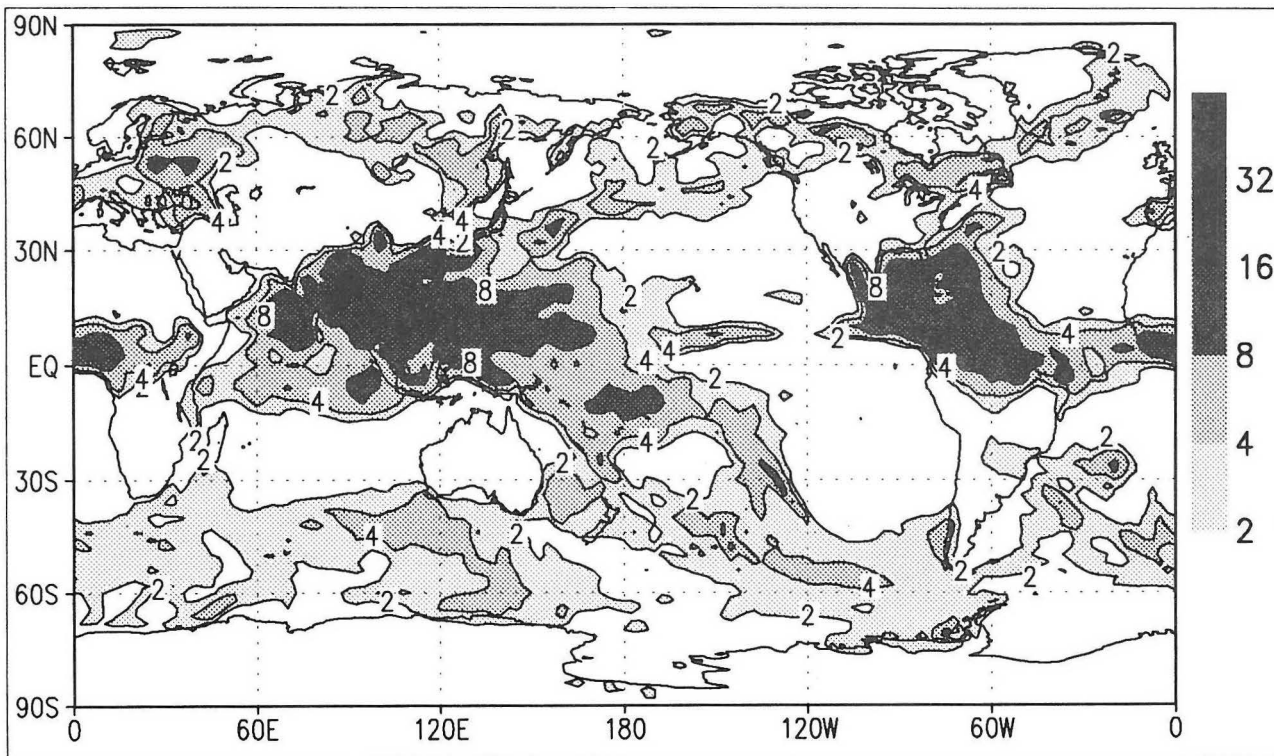

Figure 1. Radiosonde moisture analysis. Total precipitation (mm/day). June 10-24, 1988



sets need to be broadly distributed, and scientific users must provide feedback on both the shortcomings and strengths of the DAO data sets.

The present data set production is described in Schubert *et al.* (1993). The current system is evolving from a traditional atmospheric system based on optimal interpolation analysis. Special attention has been paid to improving the consistency of moist processes. Data set production is proceeding with two configurations. The main production is with the Goddard Earth Observing System - version 1, Data Assimilation System (GEOS-1, DAS). A baseline data set is being produced, which covers the period from 1985-1990, and the first two years have been completed. The full data set should be finished in early 1994. In addition, GEOS-1, DAS is being used to produce a series of TOGA/COARE (Tropical Ocean and

Global Atmosphere/Coupled Ocean-Atmosphere Response Experiment) analyses to investigate the impact of the enhanced moisture observations.

A second production is underway with STRATAN, the stratospheric version of GEOS-1. The two systems are identical with the exception of the resolution and domain of the assimilating model. Presently, the period since the September 1991 launch of UARS is being completed. In addition, there have been several shorter analyses completed for stratospheric aircraft missions. Most recently, the DAO provided operational analyses and forecasts for the Stratospheric Photochemistry, Aerosols, and Dynamics Expedition (SPADE) in April-May 1993. The DAO products proved to be the preferred field product for planning ER-2 high-altitude flights.

A high priority in the development of

the GEOS system is the representation of hydrological processes. This requires not only improvement of existing physics parameterizations in the assimilating model, but also the incorporation of extended models (e. g., land surface, cloud water, etc.) and the development of techniques to incorporate new data types. New data types will come not only from EOS, but from many other instruments in the Mission to Planet Earth. Advanced assimilation techniques will make it possible to make much better use of existing observations from both operational and research satellites.

In the figures, the ability of the current GEOS system to use moisture data and the potential impact of satellite data are explored. A series of experiments have been run. In the first experiment, a meteorological assimilation was run without using radiosonde water vapor data. In the

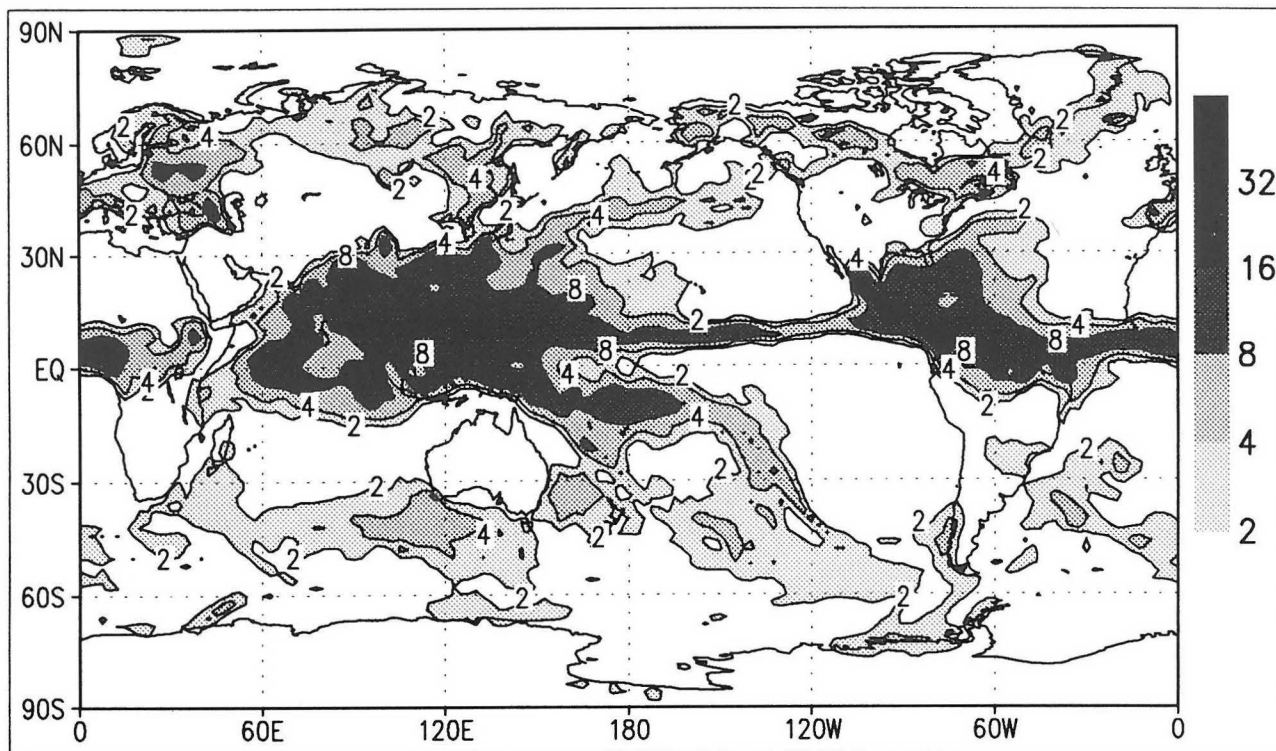

Figure 2. Radiosonde plus SSM/I vertically integrated water. Total Precipitation (mm/day) June 10-24, 1988

second experiment radiosonde water vapor data were used, and in the third experiment SSM/I (Special Sensor Microwave/Imager) vertically integrated water vapor was included.

Figure 1 shows the two-week averaged precipitation in mm/day for June 10-24, 1988 from the experiment that only incorporates radiosonde data. The radiosondes have the largest impact in Indonesia and Central and South America, and the precipitation has increased significantly in these two areas. In experiments where the general circulation model is run without the assimilation of any data, the model develops a bias where the precipitation over Indonesia is too small. This bias apparently persists in the assimilation which uses no moisture data. Outgoing longwave radiation from ERBE (Earth Radiation Budget Experiment)

has been used for qualitative verification of the precipitation pattern. The radiative information suggests that the increased precipitation in the analysis using the radiosondes is in fact an improvement. This is more than a trivial result as it suggests that the GEOS system does in fact use water vapor data in a positive way, and that this information propagates through the physics parameterizations to improve the precipitation product.

Over the equator in the eastern Pacific, there is not a distinct rain belt, as is suggested by several data sources. In fact, in the assimilation experiment with only the radiosonde data, there is a decrease in rainfall when compared with the experiment that uses no moisture data. This is apparently in response to compensating circulations that are forced when the moisture data are inserted

over the continents. Figure 2 shows the precipitation from an experiment that uses SSM/I vertically integrated water vapor. A notable change, when compared with the radiosonde-only analysis, is the precipitation band in the eastern Pacific. In addition, the band of rainfall east of Australia that extends from the north and west to the south and east is strengthened. South of Australia, there is a region where the SSM/I observations reduce the precipitation estimates.

Figure 3 shows precipitation rates derived from SSM/I by Robert Adler and George Huffman in the Mesoscale Precipitation and Dynamics Branch at GSFC. These data are independent of the water vapor data used in the assimilation, and suggest that the precipitation over the eastern Pacific is real. It can also be inferred that GEOS is in fact successfully using

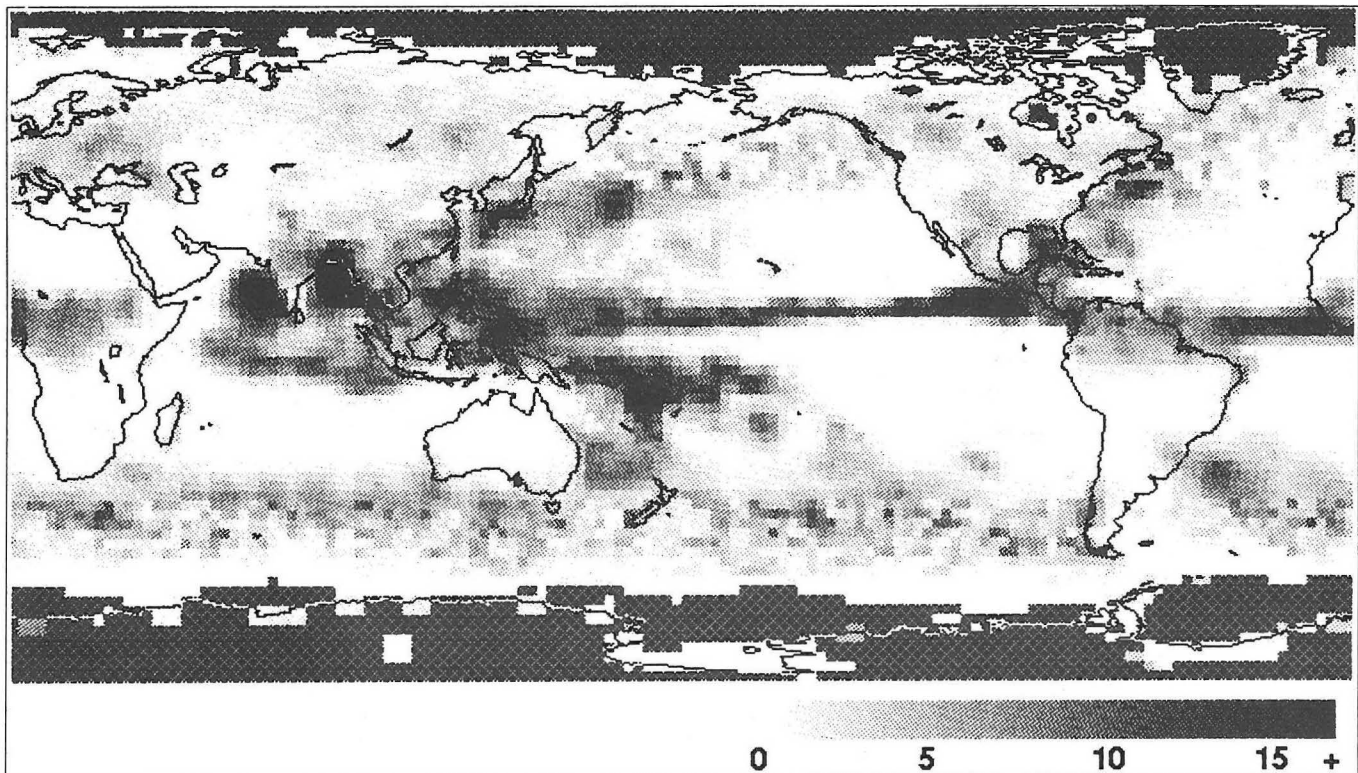

Figure 3. Gauge/satellite precipitation (mm/day) June 1988

the SSM/I water vapor data. The results show that the potential impact of satellite moisture data on the representation of important climatic processes is large.

Data from SSM/I, TRMM (Tropical Rainfall Measurement Mission), and EOS will provide not only moisture and precipitation information, but information about the vertical distribution of hydrometers. In order to accommodate these new data types, the GEOS system must be extended to include prognostic cloud water and ice. These changes are examples of the types of changes that must be made to GEOS to use the observations on the AM-1 Platform more fully. In many of these cases, not only are input and direction required from the outside community, but the DAO will require outside scientists to work with the GEOS system to incorporate important algorithm developments.

In summary, DAO data set production is underway, and the distribution of the data sets is being considered as a prototype problem for EOSDIS. Future development relies heavily on community usage and feedback about the data set performance. In addition, the DAO will require strong, hands-on input from the EOS scientists if the data assimilation system for EOS is to be generally successful and useful. Further information on the GEOS system and data set availability can be obtained by sending inquiries to [data@dao.gsfc.nasa.gov](mailto:data@dao.gsfc.nasa.gov).

#### REFERENCE

Rood, R. B., *et al.*, *J. Geophys. Res.*, **98**, 18,533-18,545, 1993. Schubert, S. D., *et al.*, *Bull. Amer. Meteor. Soc.*, **74**, 2331-2342, 1993. ■

## Availability Of Solid Particles From The Stratosphere

—Michael Zolensky ([zolensky@curate.jsc.nasa.gov](mailto:zolensky@curate.jsc.nasa.gov)), Office of the Curator, SN2, NASA Johnson Space Center, Houston, TX 77058.

### Introduction

Since May, 1981, NASA has used high-altitude aircraft to collect particles in Earth's stratosphere. Specially designed dust collectors are prepared for flight and processed after flight in an ultraclean (better than Class-100) laboratory maintained for this purpose in the Office of the Curator, Lyndon B. Johnson Space Center (JSC) in Houston, Texas. Particles are individually retrieved from the collectors, examined, cataloged, and then made available to the scientific community for research. Although the initial aim of this program was the collection of interplanetary dust particles (IDPs), presumably derived from asteroids and comets, workers have also studied the samples of terrestrial particulate (e.g. volcanic ash and aerosols, silicate dust, pollen grains) and re-entering spacecraft debris particulate that is also collected.

The most recently issued Cosmic Dust Catalog (number 13), for example, summarizes preliminary observations on 328 particles retrieved from collection surfaces L2005 and L2011. These surfaces were flat-plate Large Area Collectors (with a 300 cm<sup>2</sup> surface area each), which were coated with silicone oil (dimethyl siloxane)

and then flown aboard a NASA ER-2 aircraft during a series of flights made over west-central North America during the fall of 1989 (L2005) and 1990 (L2011). These collectors were installed in a specially constructed wing pylon which ensured that the necessary level of cleanliness was maintained between periods of active sampling. During successive periods of high-altitude (20 km) cruise, the collectors were exposed in the stratosphere by barometric controls and then retracted into sealed storage containers prior to descent. In this manner, a total of 40 hours of stratospheric exposure was accumulated for each collector. Smaller collection surfaces (exposing about 30 cm<sup>2</sup> each) are also flown throughout the year, on both the ER-2 aircraft located at Ames Research Center and a NASA WB-57 aircraft located at Ellington Field, near JSC. Typically, 2-8 collectors are flown at a time, all underneath the wings of the aircraft.

### Processing of particles

Back in the JSC clean room, collectors are either (1) stored against future need, (2) picked for cataloging and dispersal to the scientific community, or (3) made available as completely unpicked collection surfaces. Particles are individually re-



moved using glass-needle micromanipulators under a binocular stereomicroscope, rinsed of adhering silicone oil and optically characterized at 500x. Following optical description, each particle is examined (without the benefit of an applied conduc-

tive coating) by scanning electron microscopy (SEM) and X-ray energy-dispersive spectrometry (EDS). Following SEM/EDS examination, each particle mount is stored in a dry nitrogen gas atmosphere in a sealed cabinet until required. The prelimi-

nary characterization data obtained from each particle are then published in a Cosmic Dust Catalog. All such particles, as well as the unpicked collection surfaces, are available to qualified investigators worldwide.

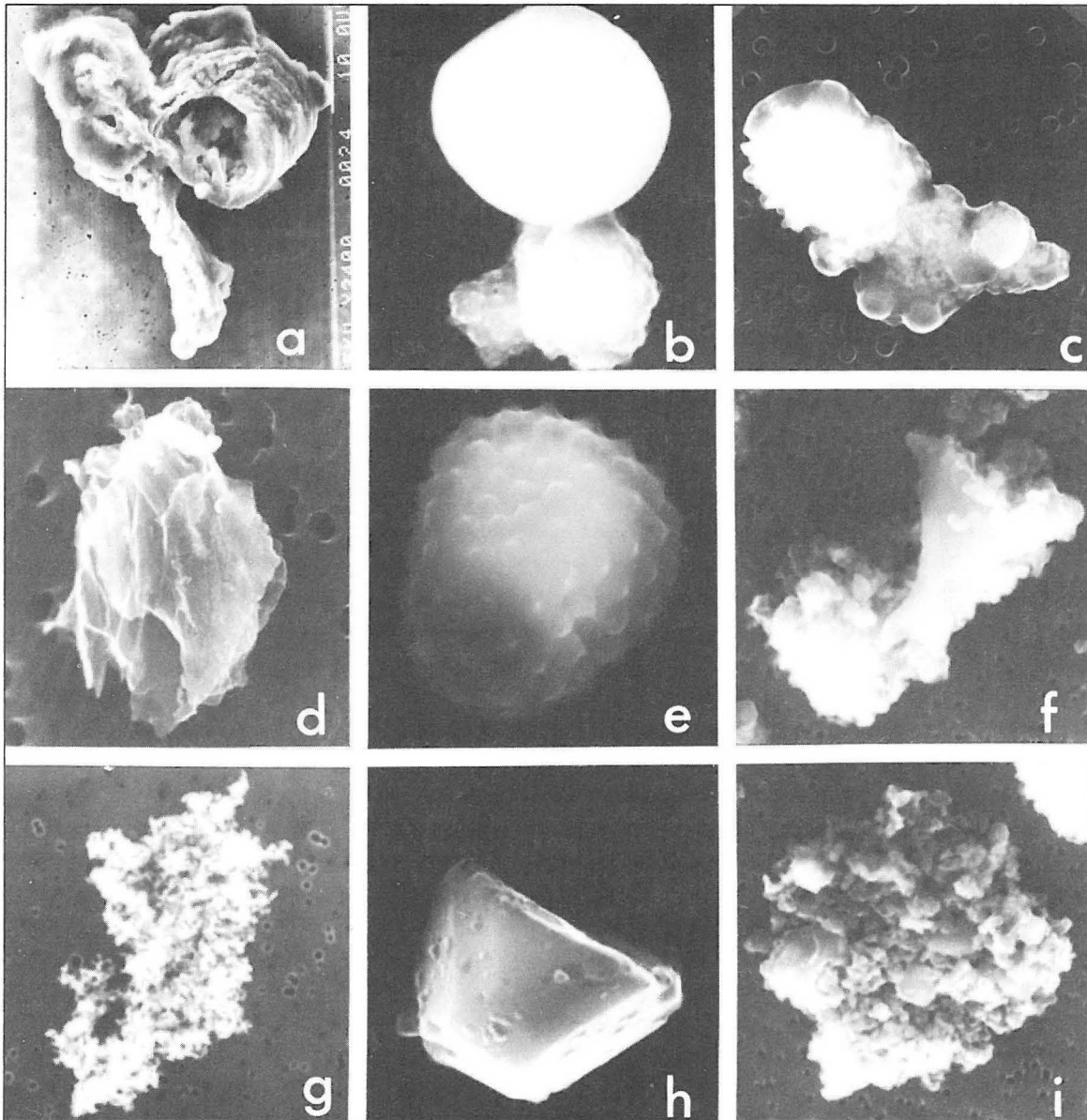

Scanning electron microscope images of particles collected in the stratosphere: (a) stainless steel (measuring  $33 \times 35 \mu\text{m}$ ) of probable spacecraft debris origin, (b) an aluminum oxide sphere attached to a piece of aluminum-iron alloy ( $7 \times 13 \mu\text{m}$ ), probably solid rocket fuel exhaust, (c) a copper sulfide grain of problematical origin ( $4 \times 8 \mu\text{m}$ ), (d) an aluminosilicate particle ( $2 \times 4 \mu\text{m}$ ), probably terrestrial dust of natural origin, (e) a pollen grain ( $20 \times 22 \mu\text{m}$ ), (f) a volcanic ash particle ( $7 \times 11 \mu\text{m}$ ), (g) a porous particle consisting exclusively of elements lighter than sodium, of unknown origin ( $8 \times 16 \mu\text{m}$ ), (h) an iron sulfide crystal ( $6 \times 8 \mu\text{m}$ ), of probable extraterrestrial origin, and (i) a porous aggregate of mineral grains with a bulk composition near that of the sun, i.e., a chondritic interplanetary dust particle ( $13 \times 14 \mu\text{m}$ ).



**Availability of terrestrial particles from the stratosphere**

NASA has been collecting dust in the stratosphere since the beginning of 1981. However, in the succeeding years full-scale particle collection has been suspended during periods of heavy volcanic particulate and aerosol content of the stratosphere. During these latter periods we have flown only one or two collectors at a time on the aircraft. Nevertheless, these particular collectors carry a record of the volcanic emissions present in the stratosphere following major eruptions.

Since 1981 the following volcanic eruptions are known to have placed material directly into the stratosphere: El Chichón (March, 1982), Nevado del Ruiz (Nov. 1985), Mt. Augustine (March, 1986) and Mt. Pinatubo (June, 1991). After each of these eruptions we have noted the presence of (generally) submicrometer-sized ash particles and aerosol droplets on collectors, although we cannot always be certain of the identity of the volcano responsible for the material. For example, collectors from March, 1981 contain abundant silicic volcanic ash from no volcanic eruption known to have directly vented the stratosphere (Zolensky and Mackinnon, *J. Geophysical Research* **90**, 5801-5808, 1985). In addition, we have noted the presence of coarse-grained (25  $\mu\text{m}$ ) volcanic ash on collectors which sampled from August 1989 to April 1990, which cannot have been derived from any of the aforementioned eruptions.

As predicted by many workers and documented by Zolensky *et al.* (*J. Geophysical Research* **94**, 1047-1056, 1989), there has recently been a dra-

matic increase of the population of spacecraft debris particulate in the stratosphere, tied to the increasing use of the atmosphere as a highway to space and the development of Earth's artificial debris belt. These re-entering grains, typically refractory oxides, silicates, alloys, and composite materials, provide nucleation sites for aerosols (Mackinnon and Mogk, *Geophysical Research Letts.* **12**, 93-96, 1985) and could have a significant effect on atmospheric chemistry.

In summary, NASA has collected and maintains representative samples of the particulate load of the stratosphere, and makes these available to

qualified investigators worldwide. While the extraterrestrial portion of these collections is actively studied, characterization of the terrestrial (and dominant) fraction of these particles lags behind. We believe that these collections are a valuable resource for atmospheric scientists interested in the origin, flux, and evolution of solid particulate in the stratosphere.

Persons desiring further information on these collections, particle catalogs, newsletters, or on preparing sample requests are invited to contact the author. ☐

EOS News— December 10, 1993

**DoE  
GLOBAL  
CHANGE  
POSTDOCTORAL  
FELLOWSHIPS**

**T**he Department of Energy established the Global Change Distinguished Postdoctoral Fellowships to support research on projects related to the U.S. Global Change Research Program (USGCRP). Fellowships are tenable at any USGCRP-agency laboratory (Departments of Agriculture, Commerce, Defense, Energy, Health and Human Services, and Interior; NASA; NSF; EPA; Smithsonian Institution; and Tennessee Valley Authority) or any university laboratory having a department with annual funding of more than \$250,000 from USGCRP agencies. The program's ultimate goal is to provide DoE and other federal agencies with highly trained and educated individuals for advancing the science of global change. Applicants must have received a doctoral degree in an appropriate discipline after April 30, 1991, and must complete all such requirements before starting an appointment between May 1 and December 31, 1994. Fellows receive a stipend of \$35,000 the first year, and may be eligible for reimbursement of moving expenses. Applications are due February 15, 1994. For further information, please contact Global Change Distinguished Postdoctoral Fellowships, Science/Engineering Education Division, Oak Ridge Institute for Science and Education, P.O. Box 117, Oak Ridge, TN 37831-0117, tel. (615)-576-9934.

# North Dakota Tracer Experiment Investigates Cloud Transport Processes

— Paul Smith, South Dakota School of Mines and Technology, Jeffrey Stith and Alan Borho, University of North Dakota; Roger Reinking and Brooks Martner, NOAA Environmental Technology Laboratory.

A major focus of the North Dakota Tracer Experiment (NDTE), carried out in the area around Bismarck during June and July 1993, was a study of in-cloud transport and dispersion processes. An article by Jeffrey Stith and John Scala in the July/August issue of the *Earth Observer* provided an overview of the NDTE along with some examples of data from the major storm that occurred on July 1. The NDTE transport and dispersion experiments used a combination of a tracer gas, sulfur hexafluoride (SF<sub>6</sub>), and radar chaff to investigate the kinematics of these processes in and around convective clouds and thunderstorms. The desire for improved understanding of the transport and dispersion of cloud seeding agents was a primary motivation, but the results of the experiments also add to our understanding of cloud processes in a more general way.

A good example of this kind of experiment occurred on July 27, 1993, in a storm northeast of the project Operations Center located at the Bismarck airport. The release aircraft, a Beechcraft Duke provided by Weather

Modification, Inc., dispensed the tracer gas and chaff simultaneously for a little over 6 minutes while flying in a ring about 10 km in diameter just below the cloud base. The release was made near 1.4 km altitude (all heights here are above mean sea level), with much of it in an updraft

of a few meters per second. Figure 1 shows part of the chaff ring visible in the reflectivity field outside the general mass of precipitation echo on the University of North Dakota (UND) C-band weather radar, just after the release had ended.

With the NOAA Environmental Technology Laboratory's circularly-polarized X-band radar located about 70 km to the west, the chaff could be followed up into the precipitation echo by looking at the circular depolarization ratio (CDR) using the TRACIR technique (Moninger and Kropfli, 1987). Whereas echoes from chaff and from hydrometers are inseparable in the reflectivity field, the chaff can be separately distinguished in the CDR field; echoes from chaff have CDR values near 0 dB, while echoes from spherical hydrometers (and many non-spherical ice particles as well) tend to give CDRs less than about -20 dB. A volume scan just after the end of the release (Figure 2) shows that parts of the chaff ring remained at cloud-base level while other parts, released into updrafts, had been carried above about 4 km altitude in convective cells with reflectivities

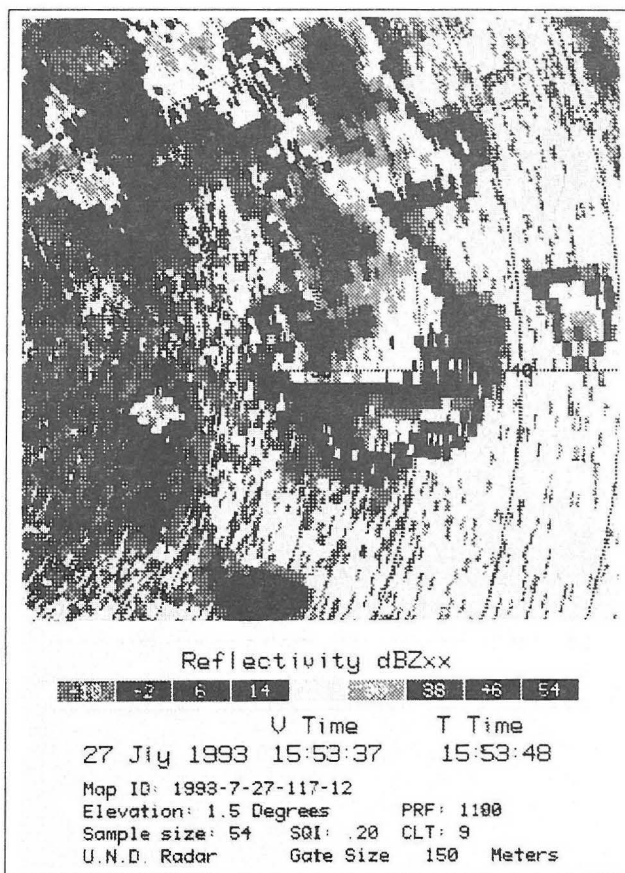

Figure 1. C-band radar reflectivity display of the 27 July 1993 storm and part of the chaff ring, just after release ended. The southern half of the ring, centered about 33 km due east of the UND radar, is visible in the lower center of the diagram (even though the chaff was cut for X-band wavelengths) and is readily distinguishable from the precipitation echo to the north.

up to 40 dBz. The chaff subsequently blended into higher-intensity precipitation echos and could no longer be clearly distinguished from the hydrometers at higher altitudes, even in the CDR data.

However, the SF<sub>6</sub> in the ascending plume was subsequently encountered by the two project sampling aircraft, each carrying a fast-response SF<sub>6</sub> analyzer. The South Dakota School of Mines and Technology T-28, penetrating the storm at 4.8 km MSL (-9° C), first found the SF<sub>6</sub> plume in an updraft (maximum about 7 m/s) a little after 1559 CDT, about 12.5 minutes after the release began (Figure 3a). It also encountered the plume again on the next pass through the cloud about 2 minutes later. There were no further plume encounters at the T-28 altitude, as by then the plume had ascended to the penetration level of the University of North Dakota Citation (initially 5.7 km MSL at -14° C). The Citation first encountered the SF<sub>6</sub> plume at about 1604 CDT, some 17 minutes after the release started. The Citation then began to ascend with the updraft air in the cloud, and encountered the plume at least three more times up to an altitude of at least 6.7 km. The last recognizable encounter, at 6.7 km (around -20° C), occurred about 27 minutes after the release began (Figure 3b).

One of the main objectives of the NDTE was to investigate transport and dispersion rates within the clouds. Experiments like that conducted on

July 27, providing multiple checks on the location and distribution of the tracer materials, produced a good set of data for experimental determination of those rates. Two- and three-dimensional cloud models will also simulate the experiments to provide a more complete view over the full cloud volume-time history; the observations will be used to evaluate and improve the simulated transport and dispersion processes in those models. A further objective of the project was to evaluate how precipitation, including hail, develops in the tracer-tagged region. This will be related to the history of the region and, when a silver-iodide seeding agent was released along with the

tracers, to the amount of that agent present.

Support for the NDTE was provided primarily through the Federal/State Cooperative Program in Atmospheric Modification Research, funded through NOAA, and the National Science Foundation Division of Atmospheric Sciences.

REFERENCE

Moninger, W. R., and R. A. Kropfli, 1987: A technique to measure entrainment in cloud by dual-polarization radar and chaff. *J. Atmos. Oceanic Tech.*, 4, pp. 75-83. ■

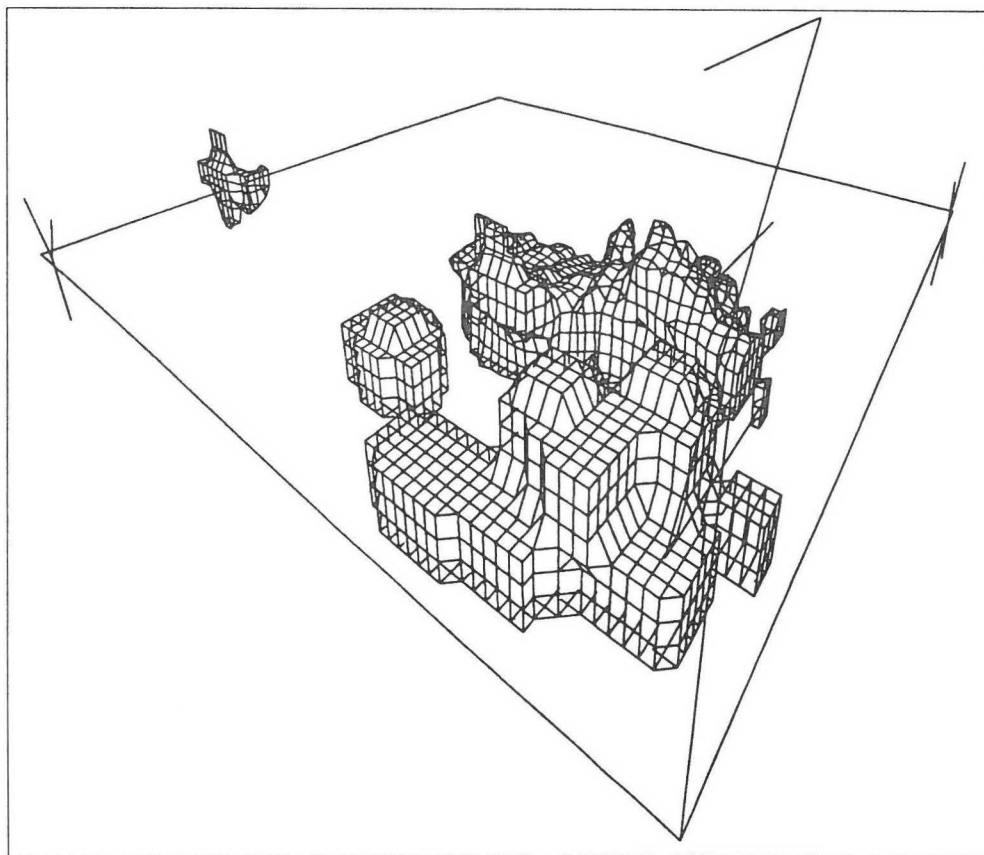

Figure 2. Perspective view of chaff (CDR > -10 dB) distribution as seen from the NOAA radar 70 km to the west, 6 minutes after chaff release began and around the same time as Figure 1. View is looking toward the northeast; domain size is 14 x 14 x 5 km.

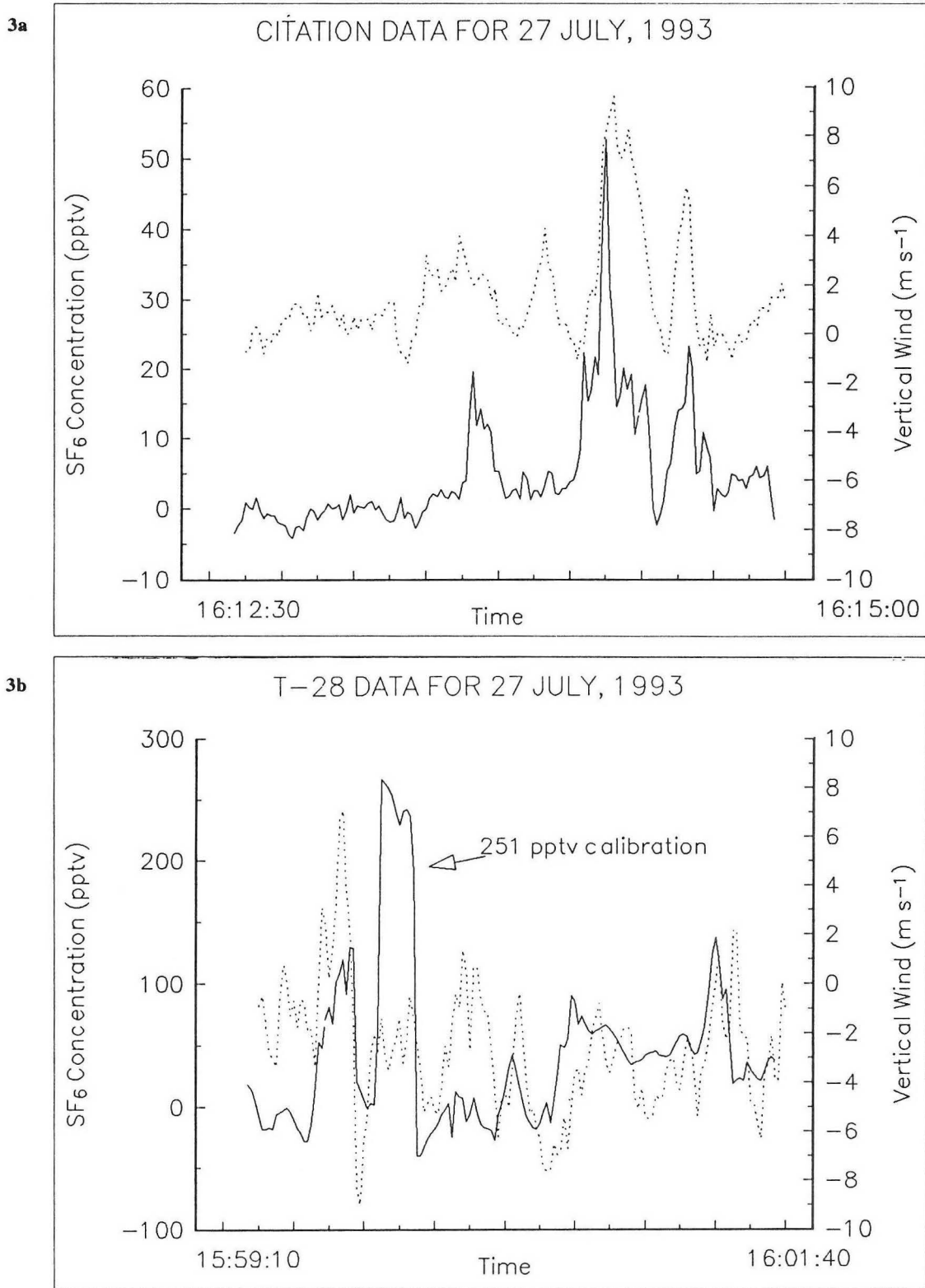

Figure 3. Traces of SF<sub>6</sub> concentration (solid line) and vertical wind (dotted line) from sampling aircraft; a) (bottom): From T-28 at 4.8 km altitude (-9°C), about 12-15 minutes after release began; b) (top): from Citation, at 6.7 km (-20°C) about 25-28 minutes after release began.



MTPE/EOS booth at the fall meeting of the American Geophysical Union in San Francisco



Ghassem Asrar (L), (EOS Program Scientist, NASA Headquarters) stops for a chat with Renny Greenstone (R), (Hughes STX Corp.)

Franco Einaudi (L), (Goddard Space Flight Center, Chief of the Laboratory For Atmospheres) gets together with Michael King (R), (Goddard Space Flight Center, EOS Senior Project Scientist) at the MTPE/EOS booth.



Winnie Humberson (R) and Renny Greenstone (L), (Hughes STX Corp.) staff members of *The Earth Observer*.

## EOS Science Calendar

• 1994 •

- February 15 AIRS Science Team Meeting, University of California at Santa Barbara, CA. Contact Hartmut Aumann at (818) 397-9534; (HHAUMANN/NASAMAIL).
- Feb. 28-Mar. 1 MOPITT Calibration Peer Review, Rockville, MD. Contact Bruce Guenther at (301) 286-5205; (guenther@highwire.gsfc.nasa.gov).
- March 1-2 GLAS Science Team Meeting, NSIDC, Boulder, CO. Contact Bob Schutz at (512) 471-4267; (schutz@utcsr.ae.utexas.edu).
- March 2 MOPITT Review, Rockville, MD. Contact Bruce Guenther at (301) 286-5205; (guenther@highwire.gsfc.nasa.gov).
- Mar. 30-Apr. 1 MISR Science Team Meeting, Pasadena, CA. Contact Dave Diner at (818) 354-6319; (DJDINER/NASAMAIL)
- April 4-6 U.S. ASTER Science Team Meeting, Seattle, WA. Contact Anne Kahle at (818) 354-7265; [sec.326/j.p.1.].
- May 4-6 (tentative) MODIS Science Team Meeting, NASA/Goddard Space Flight Center, MD. Contact David Herring at (301) 286-9515; (herring@ltpsun.gsfc.nasa.gov)
- May 23-26 7th Joint ASTER Science Team Meeting, Southern California. Contact Anne Kahle at (818) 354-4748; [sec.326/j.p.1.].
- May 25-26 TES Science Team Meeting, University of Denver, CO. Contact: Reinhard Beer at (818) 354-4748; (RBEER/GSFCMAIL)
- November 14-18 8th Joint ASTER Science Team Meeting, Japan. Contact Hiroji Tsu at +81-3-3533-9380; FAX: +81-3-3533-9383, or Anne Kahle at (818) 354-7265; [sec.326/j.p.1.].

## The Earth Observer

*The Earth Observer* is published by the EOS Project Science Office, Code 900, NASA/Goddard Space Flight Center, Greenbelt, Maryland 20771, telephone (301) 286-3411, FAX (301) 286-3884. Correspondence may be directed to Charlotte Griner (cgriner@ltpsun.gsfc.nasa.gov) or mailed to the above address. Articles (**limited to three pages**), contributions to the meeting calendar, and suggestions are welcomed. Contributions to the meeting calendar should contain location, person to contact, telephone number and e-mail address. To subscribe to *The Earth Observer*, or to change your mailing address, please call Hannelore Parrish at (301) 441-4032, send message to hparrish@ltpsun.gsfc.nasa.gov, or write to the address above.

### The Earth Observer Staff:

**Executive Editor:** Charlotte Griner

**Technical Editor:** Renny Greenstone

**Associate Technical Editor:** Bill Bandeen

**Assistant Editor:** Lynn Koert

**Design and Production:** Winnie Humberson

**Distribution:** Hannelore Parrish

## Global Change Calendar

• 1994 •

- Jan. 31-Feb. 2      Second Thematic Conference on Remote Sensing for Marine and Coastal Environments: *Needs, Solutions, and Applications*, New Orleans, Louisiana. Contact Robert Rogers, ERIM, P.O. Box 134001, Ann Arbor, Michigan 48113-4001, phone: (313) 994-1200, ext. 3234, FAX: (313) 994-5123.
- Feb. 18-23          American Association for the Advancement of Science, San Francisco, California. Contact Stephanie Brooks, phone: (202) 326-6711.
- Feb. 21-25          Ocean Sciences Meeting, San Diego, Calif. Sponsors: AGU; ASLO. Contact AGU Meeting Dept., 2000 Florida Ave., N.W., Washington, DC 20009; phone: (202) 939-3203.
- March 1-4            7th Australasian Remote Sensing Conference, Melbourne, Australia. The Conference will be held in conjunction with: 1) The Inter-Congress Symposium of Commission 5 of the International Society for Photogrammetry and Remote Sensing (ISPRS), 2) The second Australian Photogrammetric Conference, and 3) The Pacific Ocean Remote Sensing Conference (PORSEC 94). Contact: Michael McLean/Secretary to the Organizing Committee, 7th ARSC Conference Secretariat, P.O. Box 29, Parkville, Victoria 3052 Australia, phone: (03) 387 9955, FAX: (03) 387 3120.
- March 8-11          Oceanology International 94, Brighton, UK. Contact Lesley Ann Sandback, Spearhead Exhibitions Ltd, Rowe House, 55-59 Fife Road, Kingston upon Thames, Surrey KT1 1TA, UK, phone: 081 549 5831 (International: +44 81) FAX: 081 541 5016 or 081 541 5016 (International: +44 81).
- March 29-April 2    Association of American Geographers 1994 Annual Meeting, San Francisco, California. Contact Ronald Ablor, 1710 16th St. N.W., Washington, D.C. 20009-3198, phone: (202) 234-1450; FAX: (202) 234-2744, Internet: aag@gwuvm.gwu.edu; Bitnet: AAG@GWUVM.
- March 30-April 2    Seventh Annual Geographic Information Systems Conference, sponsored by the Department of Geography and Environmental Planning at Towson State University. Contact John M. Morgan, III, Department of Geography and Environmental Planning, Towson State University, Baltimore, Maryland 21204-7097, phone: (410) 830-2964, FAX: (410) 830-3888, Internet: e7g4mor@toe.towson.edu.
- April 4-8            SPIE's International Symposium on Aerospace Sensing, Orlando, Fla. Sponsor: The International Society for Optical Engineering. Contact: SPIE, PO Box 10, Bellingham, WA 98227-0010, phone: (206) 676-3290; FAX (206) 647-1445; e-mail: spie@mom.spie.org.
- April 12-15          Second Annual Catalog Interoperability/NASA Science Internet Workshop (CI/NSI), Arlington, VA. Contact: Angelia Bland at (301) 441-4299; bland@nssdca.gsfc.nasa.gov.
- April 26-28          1994 ASPRS/ACSM Annual Convention & Exposition, Reno, Nevada. Contact: Denise Cranwell, phone: (301) 493-0200.
- May 9-12            Tenth Thematic Conference on Geologic Remote Sensing: *Exploration, Environment, and Engineering*, San Antonio, Texas. Contact Robert Rogers, ERIM, P.O.Box 134001, Ann Arbor, Michigan 48113-4001, phone: (313) 994-1200, ext. 3382, FAX: (313) 994-5123.
- May 23-27          1994 American Geophysical Union Spring Meeting, Baltimore Convention Center, Baltimore, Maryland. Contact Sherry Washington, 2000 Florida Avenue, N.W., Washington D.C. 20009, phone: (202) 462-6900, FAX: (202) 328-0566.
- September 5-9      Call for Papers for ISPRS Commission III Symposium, *Spatial Information from Digital Photogrammetry and Computer Vision*, Munich, Germany. Contact Christian Heipke, Secretary, ISPRS Commission III 1992-1996, Chair for Photogrammetry and Remote Sensing, Technical University Munich, Arcisstr. 21, D-80290 Munich, Germany. Phone: +49-89-21052671 (2677), FAX: +49-089-2809573, or Email: chris@photo.verm.tu-muenchen.de.
- September 11-15    First International Airborne Remote Sensing Conference and Exhibition: *Applications, Technology, and Science*, Strasbourg, France. Contact Robert Rogers, ERIM, Box 134001, Ann Arbor, Michigan 48113-4001, phone: (313) 994-1200, ext. 3234; FAX: (313) 994-5123.

Code 900  
National Aeronautics and  
Space Administration

Goddard Space Flight Center  
Greenbelt, Maryland 20771

Official Business  
Penalty For Private Use, \$300.00

Postage and Fees Paid  
National Aeronautics and  
Space Administration  
NASA-451

