

# THE EARTH OBSERVER

An EOS Periodical of Timely News and Events

Vol. 4, No. 5

September/October 1992

## Inside

### PANEL REPORTS

Adapting the Earth Observing System to the Projected \$8 Billion Budget 3

### SCIENCE TEAM MEETINGS

SAGE III Science Team Meeting 11

MISR Cloud Masking Workshop 13

### ARTICLES

Volcanology IDS Team meets for Eruption Plume Meeting 17

New Tools for Working With Spatially Non-Uniformly-Sampled Data from Satellites 19

### ANNOUNCEMENTS

A New NOAA Bulletin 10

Infrared Calibration Symposium 16

The Earth Observer Subscription 26

EOS Science Calendar 26

Global Change Calendar 27

## Editor's Corner

**O**n September 15, 1992, I replaced Jeff Dozier as EOS Senior Project Scientist. We wish Jeff well as he returns to his teaching and research career at the University of California, Santa Barbara. Jeff performed an enormously valuable service to the entire Earth Science community during a period of profound change and restructuring of the EOS Program. During the past year, the EOS-A and EOS-B platforms were recast into six smaller platforms having more focused objectives. Is EOS now a more stable program, simply ready for instrument and software development with no more surprises? I think it would be unrealistic and unwise for any of us to think so.

In spite of the well-articulated and focused program, developed in close consultation with the Payload Advisory Panel and the IWG, the budget realities in the Congress have again dictated that the EOS Program narrow its focus and reduce its budget. The recently passed Appropriations Bill in the U.S. Congress further reduced the decadal funding for EOS from \$11 billion to \$8 billion, all to be absorbed between fiscal years 1994 and 2000. In anticipation of this decision, and following on the heels of the Red and Blue Team recommendations to the NASA Administrator, the Payload Advisory Panel was once again convened (see Payload Panel Report elsewhere in this issue).

(continued)

A number of events have occurred since the Payload Panel met in Herndon, VA during early September. First, the Conference Committee of the Congress met to resolve differences between the Appropriations Committees of both Houses of Congress. The surprising language in the Senate Appropriations bill that the \$8 billion cap on the EOS budget through fiscal year 2000 should be considered to be "a new funding floor below which the project shall not go" was deleted. The Congress also initiated a "cap on the amount of funds for instruments specified for each EOS platform, including EOS AM-1." This has the effect of pooling any instrument contingency funds available to the Project such that the use of funds by one instrument on a platform leaves less available for other instruments on the same platform. On the other hand, it eliminates the possibility of any platform (e.g., EOS AM-1) using funds earmarked for some other platform (e.g., EOS PM-1).

Second, the EOS Program office has indicated to the European Space Agency (ESA) the criticality of MIMR for the PM-1 mission.

Third, the MISR polarization proposal recommended by the Payload Panel has been withdrawn. This decision was a joint one, based partly on available funding and the necessity for early funding to achieve a robust design. In addition, the option of adding polarization to perhaps a later version of MISR was considered, but it appeared that even this option increased cost as well as added risk (i.e., the need for contingency). The MISR team was naturally uncomfortable with assuming more risk and thereby potentially jeopardizing the MISR instrument entirely.

Fourth, the NASA Administrator has decided to accept the Red and Blue Team recommendations to eliminate HIRIS from the EOS complement of instruments. There is nevertheless funding for 2 years for the HIRIS Science Team to continue its investigation of the use of high-spatial-resolution spectrometry to study canopy chemistry. Options to fly a modified HIRIS instrument on either Landsat-8 or an Earth Probe will benefit from this very important science investigation.

Fifth, the Payload Panel recommended a timely selection between MLS and SAFIRE for the

EOS-Chemistry mission. In response to this recommendation, the EOS Chemistry and Special Flights Project convened a Science, Technical and Cost Review of MLS on October 15 and SAFIRE on October 16. These reviews reexamined the science objectives of each instrument and the instrument design to support the objectives. Both the MLS and SAFIRE teams were provided with a set of guidelines, which included the Report of the Atmospheres Panel of December 19, 1991, the minimum set of required measurements presented at the September Payload Panel Meeting, the total funding available, and the initial funding profile to be used for planning purposes. Each team was instructed to account separately for contingency, and not to rely on Project contingency. These two-day reviews were attended and evaluated by an Engineering Team, a Project Management and Cost Team, and a Science Team. A decision arising from this review will be announced shortly.

Sixth, Len Fisk has selected Hughes Information Technology Company for negotiating a contract for the EOSDIS Core System. As there was no protest filed, NASA is now proceeding to negotiate a contract with HITC for an award of the ECS contract.

Finally, I look forward to working with each of you in the ensuing months and years to implement an EOS Program that the entire scientific community can embrace as both well conceived and valuable to society. We have a daunting responsibility and an important challenge ahead. □

—*Michael King*  
*EOS Senior Project Scientist*

## Adapting the Earth Observing System to the Projected \$8 Billion Budget: Recommendations from the EOS Investigators

Edited by:

—*Berrien Moore III*, Institute for the Study of Earth, Ocean and Space, U. of New Hampshire, and

—*Jeff Dozier*, Center for Remote Sensing and Environmental Optics, U. of California, Santa Barbara, CA

### Panel Report

**W**e present here in its entirety the Executive Summary of the report of the EOS Payload Advisory Panel resulting from a meeting held in Herndon, Virginia, September 8-10, 1992. The report, *Adapting the Earth Observing System to the Projected \$8 Billion Budget: Recommendations from the EOS Investigators*, October 14, 1992, was edited by Berrien Moore III, Chairman of the EOS Payload Advisory Panel and Jeff Dozier, former EOS Project Scientist. The report was prompted by the recently passed appropriations bill in the U.S. Congress, which reduced the decadal EOS budget from \$11 Billion to \$8 Billion, and by the NASA Red/Blue Team recommendations for reducing the EOS budget accordingly.

### Executive Summary: Synopsis of Recommendations for the \$8 Billion Program

We believe that a properly structured \$8 billion funding profile through the rest of this decade is enough to design and put in place the initial components of the

Earth Observing System (EOS), NASA's major contribution to the Global Change Research Program. The purpose of EOS is to study and understand natural and anthropogenic changes in the Earth System. The EOS

---

**“The report was prompted by the recently passed appropriations bill in the U.S. Congress, which reduced the decadal EOS budget from \$11 Billion to \$8 Billion, and by the NASA Red/Blue Team recommendations for reducing the EOS budget accordingly.”**

---

program will include an integrated space-based observing system, creation of a global data base of crucial measurements that span a 15-year period, development of better predictive models

so that plausible changes can be understood, and a comprehensive data and information system that fosters synergistic interactions between observations and models and enables and encourages interdisciplinary research.

We note, however, that the descope of EOS to \$8 billion requires difficult tradeoffs to maximize science in a cost-driven program. One key choice is the amount of contingency held to handle unexpected problems in instrument development and changing science requirements driving the specifications for the instruments and data system. This contingency must be balanced against the savings that would result from complete elimination of instruments and their associated scientific information.

We favor reducing this contingency and therefore accepting a loss in future EOS flexibility. The reduction last year from \$17 billion to \$11 billion has already



reduced EOS to a minimum set of instruments to pursue the focused objective of global climate change. In this latest reduction, the measurement capabilities of the remaining instruments were significantly reduced. Further reductions are not reasonable.

The increase in risk associated with the reduction in contingency is implicitly mitigated because EOS is a long-term measurement program, with instruments flown on five-year intervals. Consequently, instrument development problems or changes in science specifications could be handled in the next versions of the instruments. The first copies of some instruments may be deficient. For example, instruments with detector arrays may have some failed detectors at launch, or instrument noise may be greater than specification. Some problems can be fixed in later data processing; others will require correction in later versions of the instruments. Some level of resilience and flexibility, however, must be maintained to allow EOS to be carried out under normal (expected) levels of uncertainty in the budget and also to allow for the necessary technology developments that benefit U.S. competitiveness.

At \$8 billion, EOS must depend increasingly on our European and Japanese partners. Failure to accomplish planned international cooperation on ADEOS, POEM, TRMM, and their follow-on missions will leave gaping holes in the international Earth Observing System. We note that in the \$8 billion program, the U.S. is relinquishing to international partners the development of new advanced

technologies in laser and active microwave remote sensing. Finally, any further budget cuts will require wholesale elimination of information critical to understanding global climate change.

In developing our recommendations we considered carefully the proposals of the Red/Blue Team. Their recommendations are carefully constructed and we applaud their efforts. Generally, the Payload Advisory Panel concurs with the Red/Blue Team. There are, however, important differences. We summarize the differences by highlighting some of the Panel's recommendations and contrasting them to those of the Red/Blue Team. Our recommendations are discussed more fully in the sections that follow this one. The major recommendations that deal with program additions (Sections 1.1-1.4) are discussed roughly in order of priority. The recommendation (Section 1.6) about the Wide Band Data Collection System may lead to an additional deletion and cost saving and is considered high priority.

### 1.1 High-Resolution Imaging Spectrometer

- The Panel recommends that the current HIRIS science investigation continue as planned through its projected completion in 1994. This effort will provide the foundation for imaging spectrometry of canopy chemistry and other applications in the Earth sciences, whether such measurements remain in EOS, migrate to Landsat 8, or find some other venue.

The Red/Blue Team recommended cancellation of HIRIS. The Payload Advisory Panel concurs that the original HIRIS is too expensive for an \$8 billion program. However, we believe that a solid case exists for an imaging spectrometer with the spectral resolution and the spectral coverage of HIRIS, but with lower spatial resolution. Our recommendation seeks to learn more fully the basis and strength for that case. In the body of this Report, we make several specific recommendations about imaging spectrometry. We do not recommend that development of the currently envisioned HIRIS II instrument be accelerated. We do recommend a modest study of a new imaging spectrometer to help estimate future costs of a lower-spatial-resolution instrument while the science requirements for canopy chemistry are better defined and while the use of imaging spectrometer data in other important Earth science applications is further explored.

### 1.2 Instruments for Stratospheric Chemistry and Dynamics

- The Payload Advisory Panel supports the Red/Blue Team proposal to fly the EOS-Chemistry package in about 2002. EOS-Chemistry with HIRDLS, MLS, SAGE III, and SOLSTICE satisfies all minimum requirements. If SAFIRE is substituted for MLS, the mission satisfies all minimum requirements except for ClO measurement. A timely selection between MLS and SAFIRE should be done, and the selection process should include a technical review of each instrument.



- We recommend that two SAGE flights be carried out by the year 2000. Continuity of the data record will be more useful if later flights can overlap previous ones. We also reiterate the need to have simultaneous flights with both polar and inclined orbits to achieve global spatial distributions. Because of the enhanced capabilities of SAGE III, the Panel recommends flying it rather than SAGE II, as soon as possible.

Global stratospheric measurements of temperature, winds, aerosols, and clouds, long-lived trace gases, some radical and most reservoir species are needed because these quantities can vary strongly, both spatially and seasonally. Long-term, high-precision, continuous monitoring of ozone, temperature, and some reservoir gases is needed for global trends. Measurements and mapping at fine spatial resolution are required to examine the mixing process in the polar vortex, and the troposphere-stratosphere exchange. They are also needed to resolve localized stratospheric synoptic-scale events that can produce important localized regions of heterogeneous chemical reactions and ozone depletion.

ESA's POEM-ENV package, which is likely to fly in 1998, may include GOMOS, MIPAS, and SCIAMACHY. The package will measure many of the required species, but it lacks capability to measure the key radical OH; it measures ClO only under ozone hole conditions where the concentration exceeds 1 ppb; and it does not measure key reservoir species in the chlorine and

bromine families (HCl and HBr). None of the POEM-ENV instruments provides the high-horizontal-resolution data available from HIRDLS.

The ESA measurements will contribute to our understanding of stratospheric processes and to monitoring global trends. The flight of ESA's POEM-ENV in about 1998, followed by the flight of EOS-CHEMISTRY post 2000, would provide a valuable time series of many important stratospheric variables. Currently, we have insufficient information about the sensitivity and precision of the constituent measurements and the risk associated with the ESA instruments. As a consequence, the Payload Advisory Panel plans to invite the principal investigators of MIPAS, GOMOS, and SCIAMACHY to address the panel about the space heritage and risk associated with the instruments, and about the sensitivity and precision of the measurements of temperature, aerosols, and constituents that will be possible.

Finally, the Payload Advisory Panel iterates the recommendations made previously by itself, and by the Atmospheres Panel. We recognize that an additional flight of SAGE is above and beyond the Red/Blue Team recommendation.

### 1.3 Measurements of Tropospheric Aerosol

- We recommend that the proposed MISR polarization measurement on the EOS AM-1 be included expeditiously by the EOS Project to further the capability of deriving global distributions of aerosol properties from space.

Tropospheric aerosols have been posed as a possible paradigm for understanding many of the dominant discrepancies between patterns of temperature increase that are measured, as opposed to inferred, from climate models for global warming. EOS observations can make important progress toward the resolution of this issue by global mapping of tropospheric aerosol opacities on a time scale of a few days out to interannual.

The EOS aerosol workshop in December 1991 recommended an assessment of the capability of EOSP under realistic conditions through simulation and field ground truth measurements to provide unique additional information through its polarization capability. A preliminary assessment is currently being carried out by the EOSP team which, if successful, supports the inclusion, as recommended by the Red/Blue Team, of EOSP on the second EOS-AM platform.

The MISR team proposes adding a polarization measurement on the EOS AM-1 platform through a relatively minor enhancement of its MISR instrument. The data would be used by the EOSP team to refine and validate their algorithms for deriving global fields of aerosol opacities using polarimetry.

### 1.4 Solar Irradiance Monitoring

- We recommend that plans be made for prompt flight (within the next 3-4 years) of solar monitoring from a small satellite or from a flight of opportunity. A flight would need to occur within the next several years if it is to have a

good chance of connecting with UARS. The method for continuation of solar monitoring after this first "gap filler" should be determined soon, i.e., within the next year or so.

- Solar spectral variability is an important aspect of solar variability for climate purposes. Climate forcing due to changes of solar irradiance depends on the spectrum of the changes. To a large degree, the arguments about the need for overlap of successive instruments apply to monitoring of the spectrum, as well as to monitoring the total solar irradiance. The length of existing record at risk due to a potential gap in monitoring is much less for the spectral radiance. We recommend that plans for prompt flight of continued solar monitoring include SOLSTICE as well as ACRIM.

Solar monitoring of irradiance variability is crucial for issues of long-term climate change. Satellite monitoring during the past decade confirms the existence of significant total solar irradiance variations of about 0.1%. It is important to know whether there are larger variations on longer time scales. Measurement of solar irradiance change relies on instrumental precision. Consequently, temporal overlap of the instruments is required. The Shuttle ACRIM calibration is aimed at this problem, but there is not yet proof that this experiment will eliminate the need for overlapping instruments to provide an adequate long-term record. Moreover, of the solar irradiance instruments currently

flying, the one with the potential for longest life is probably ACRIM II on UARS; however, it is unlikely that its lifetime will be more than a few years.

The first identified flight (following the Red/Blue Team recommendation) of ACRIM (and SOLSTICE) is on CHEMISTRY 2002, which implies a large gap in solar monitoring.

### 1.5 Descoping or Failure to Fund Major Instruments: AIRS, MODIS, LAWS, EOS SAR

#### *Descoping of the Atmospheric Infrared Sounder (AIRS)*

We support the Red/Blue Team's recommendation to reduce AIRS from two spectrometers to a single spectrometer. We caution, however, that the modifications eliminate some important measurements of cloud emissivity and water vapor at fine vertical resolution near the surface. AIRS still can provide temperature and humidity profiles at the accuracy needed to improve climate modeling and numerical weather prediction.

AIRS has been reduced from two spectrometers to a single spectrometer, which effectively cuts the spectral coverage by half. Elimination of full spectral coverage will possibly reduce the accuracy of the spectral calibration in some IR channels. In addition, the signal-to-noise requirements and the resulting NE $\Delta$ T, which had been relaxed previously to 0.35° C in the 15  $\mu$ m region and 0.2° C in the 4  $\mu$ m region, must now revert to the original requirements of nearly 0.1° C throughout the spectrum.

This results from the reduction of detector elements that previously provided the required accuracy and redundancy by co-addition of their signals. The end result is an intrinsically less-reliable focal plane with more demanding requirements on optics, detectors, filters, and signal-to-noise ratios to achieve the goals of AIRS for EOS and NOAA.

The loss of AIRS' full spectral coverage will result in gaps for determining the infrared spectral emissivity of clouds and the surface. We also have lost the opportunity to test and verify a new concept for determining humidity (from daytime observation in the 3.4  $\mu$ m region) with a vertical resolution of just a few hundred meters above the surface, and we have relinquished the capability to map globally the horizontal distribution of several important trace atmospheric gases.

With strict adherence to the original signal-to-noise requirements, we believe that AIRS still can achieve its basic science goal to provide temperature and humidity profiles with the same accuracy and resolution originally specified.

#### *Descoping of the Moderate-Resolution Imaging Spectroradiometer (MODIS)*

- Because of the pivotal role of the MODIS instrument in supporting other instruments and in providing key products for several land, ocean, and atmosphere studies, we urge that Project and Program proceed carefully before instituting any further reductions in the specifications and capability of MODIS.

The original MODIS was descoped in the previous restructuring by eliminating the tilting instrument, MODIS-T. The current instrument is being reviewed further and contingency is being cut. Among the suite of descoping options being considered are detector performance, band-to-band and focal-plane-to-focal-plane registration, and in-flight calibration. The MODIS Science Team is considering the implications of the suggested descoping.

***Laser Atmospheric Wind Sounder (LAWS)***

- We encourage NASA to develop interagency and international partnerships involving the LAWS team, that would lead to achieving measurements of the tropospheric wind field.

The LAWS instrument will provide critical information on the tropospheric wind field. However, its flight requires both a separate platform and additional funding.

***Multipolarization, Multifrequency Synthetic Aperture Radar (EOS SAR)***

- We encourage NASA to develop interagency and international partnerships to design and build a multifrequency, multipolarization SAR that will address the broad science objectives of global climate change.

EOS SAR is required to measure globally biomass, soil moisture, snow accumulation, and polar ice dynamics. The proposed EOS SAR instrument has been descoped to

provide the minimal capability to measure key parameters in ecosystem dynamics, hydrology, solid Earth, and cryospheric science.

**1.6 Wide Band Data Collection System (WBDCS)**

- At the next Payload Advisory Panel Meeting, the WBDCS Team should be prepared to justify the inclusion of the WBDCS on an EOS platform in the context of other EOS priorities.

The Payload Advisory Panel recognized the potential value for the direct broadcast of geophysical data using a satellite relay system. Earthquake monitoring, tsunami warning, snow-fall data, and real-time alert of volcanic eruptions are some of the potential fields that would benefit from such a system. The Red/Blue Team recommends the WBDCS for flight on PM-1. As currently defined, however, the Panel felt unable to endorse the flight of the WBDCS on any specific EOS platform without additional information on data rate requirements and the necessary tracking capabilities of the ground stations.

**1.7 Scatterometer Data for EOS**

- The Payload Advisory Panel reaffirms the necessity of flying an NSCAT-class scatterometer throughout the EOS time frame. Specifically, the Panel encourages continued discussions between NASA and NASDA for the flight of NSCAT-2 on the ADEOS-II mission, scheduled for launch in 1999. Such a flight and its follow-ons assure

continuity of the time series of ocean wind measurements begun by NSCAT/ADEOS-I and will provide a unique data set through simultaneous scatterometer, microwave radiometer, and ocean color measurements.

Scatterometer measurements of wind velocity (both speed and direction) are crucial for studies of the ocean's role in climate variability, wind-forced upper ocean circulation and heat transport, regional and basin-wide air-sea interaction, marine meteorology, and ocean productivity. In the operational arena, scatterometer measurements of surface wind velocity can be assimilated into regional and global atmospheric forecast/analysis systems to yield improved weather forecasts.

Because climatically important oceanic and air-sea interaction processes occur over a wide range of temporal and spatial scales, measurements of key dynamic variables must be obtained frequently and with high resolution. These measurements must extend over long periods and have extensive coverage. The sampling characteristics of a two-swath, NSCAT-class scatterometer in the ADEOS orbit allow coverage of more than 95% of the global oceans every two days with 50 km resolution. NSCAT-2 will be a near-copy of NSCAT (in terms of frequency, measurement technology, sampling, and ground processing). Launch on ADEOS-II (before the planned end of the ADEOS-I mission) will ensure a continuous, multi-year data set of consistent wind velocity measurements.



### 1.8 Satellite Radar Altimeter

- We recommend that NASA proceed immediately to identify and secure funding to proceed with a joint U.S./France TOPEX follow-on mission to launch in 1998
- As an alternative, the concept of moving the EOS-ALTIMETRY mission forward to near 1998 should be examined. The possibility of combining TOPEX follow-on and EOS-ALTIMETRY along with the option for flying the GLAS in this period offers the possibility of cost savings in the overall cost profile of the Mission to Planet Earth.

The importance of altimeter data in developing an understanding of ocean circulation has led to the TOPEX/Poseidon mission. The accuracy of the TOPEX sea-surface height measurement is not matched by any current or previous satellite altimeter missions. To evaluate changes in global ocean circulation patterns and global mean sea-level over decadal time scales requires that the EOS-ALTIMETRY missions preserve the height measurement accuracy of the TOPEX/Poseidon system.

Although the currently considered concept of a CNES-provided solid state altimeter and a DORIS tracking system for POD provides a promising approach, it is important that the capabilities of the CNES package meet TOPEX/Poseidon standards. The Panel will continue to monitor the TOPEX follow-on mission.

The most pressing issue concerns funding for TOPEX follow-on. To

meet a 1998 launch date, TOPEX follow-on would need to begin Phase C/D in FY 1995. This means that efforts must begin in early 1993 to identify funding. Since this mission should be funded under the Earth Probe line, it is critical that the Earth Probe line in FY95 be maintained at the FY94 year level plus inflation. Such a mission would have the broad support of the oceanographic community and is critical to a number of global change objectives. Moreover, it should be of relatively low cost, given the joint France/U.S. involvement.

The Red/Blue Team recommendation supported only an ALTIMETRY mission in 2002 and did not address or recommend a more-timely oceanographic mission.

### 1.9 International Instruments of EOS Platforms

#### ASTER

- ASTER should be flown to provide subpixel variability of surface temperature, mineral composition, surface topography, and three-dimensional mapping of volcanic plumes.
- ASTER should be flown out of phase with Landsat 7 for eight-day interleaved coverage.
- Cooperation with NASDA, whereby we fly ASTER on EOS AM-1 and they fly NSCAT on ADEOS and CERES and LIS on TRMM, is crucial to the EOS mission's dynamical observations.

Given the possibility that Landsat 7 will fly in 1997 or 1998, the role and cost of ASTER must be

carefully examined. The Panel discussed the issues associated with ASTER and concluded that Landsat 7 is complementary to ASTER. It does not replace the need for ASTER.

#### MIMR

- Given the possibility that new microwave radiometers may be flown by the U.S. Department of Defense, ESA, and NASDA in 1998-2000, we need to consider the desirability of overlap of so many similar instruments.

ESA is considering building MIMR for both EOS PM-1 and POEM AM spacecraft. A decision on this plan may be made at the European Ministers meeting in November. This issue needs to be revisited at the next Payload Advisory Panel meeting.

### 1.10 EOS Data and Information System

#### EOS Data Products

- The Red/Blue Team has started the process of refining the list of science data products to be provided in EOSDIS. However, the EOS investigators cannot relinquish responsibility for this task. Hence the science panels and instrument teams of the EOS Investigators Working Group must systematically develop the list of core data products, including science requirements, algorithm heritage, alternative approaches, and intermediate products.
- The EOS Project must work with the appropriate EOS

investigators to better estimate the data system loads associated with each product, and to consider whether the data product should be produced routinely or only on demand. They also should consider whether the coded algorithm could be distributed instead of the calculated data product.

Evaluation of the relationship between the cost of EOSDIS and the list of high-priority data products requires analysis of the science, algorithms, products, and the associated requirements on EOSDIS for systems engineering, processing, archive, and distribution. The EOS IWG recognizes that it must play an active role in the definition and development of EOS data products.

*Transition from Version 0 to Version 1*

- The EOS Project must work with the science community in the development of the transition from EOSDIS Version 0 to Version 1 to ensure that necessary services are maintained and that required capabilities are added in an orderly manner. The transition must be examined in the context of the types of science problems and information system technology that will be available in the mid-1990s.

The release of Version 1 is scheduled to occur 2 years after the release of Version 0. The EOS Project must adequately plan for the transition between these two efforts, to ensure that the Version 0 capabilities evolve smoothly into

Version 1. The ECS contractor must study the designs, results, and experience from the Version 0 effort and assess the feasibility of using Version 0 products in the development of Version 1. The specific steps in the transition—determined by the EOS Project, the ECS contractor, and the EOSDIS Advisory Panel—must be based on these assessments, experience at the DAACs, science user feedback, technical factors, and cost.

*EOSDIS User Model*

- The EOS Project must develop a user model—numbers of users and their characteristics—that is based on investigators' proposed work with EOS instruments, on existing scientific data production systems, and on processing scenarios and benchmarks.
- The EOSDIS IV&V (Independent Verification and Validation) contract must support the EOS Project's effort to examine the system from the scientific users' viewpoints. It must not be merely a requirements-tracing exercise.

Establishment of users' requirements for EOSDIS is difficult, because they will change as the interaction between the Earth and information science communities improves and as scientists gain experience in using the tools developed by the ECS contractor. To evaluate the effectiveness of EOSDIS from the scientists' perspectives, end-to-end scenarios and benchmarks will be needed that use representative data sets to address science issues, to evaluate the functional capabilities of

EOSDIS, and to measure the performance of the system.

*Effects of Budget Reductions on EOSDIS*

- The EOS IWG (through its EOSDIS Advisory Panel) must examine the architecture, design, and assumptions of the newly selected contractor, and analyze the cost sensitivity of the system's attributes. The IWG can then assess where costs might be reduced.

The significant steps in meeting the 30% reduction include reduction of the suite of data products available at launch to about 100 Level 2 products and about 100 additional Level 3 and 4 products, and deferred migration of existing data sets into Version 0 (in cases where the data are available through an existing operational system), and reduction in contingency.

*Other Procurements: EDOS, ECOM, IV&V*

- NASA should design flexibility into EOSDIS to support network data delivery via networks whenever economically feasible and plan for the insertion of National Research and Education Network (NREN) technology in EOSDIS when it is operationally available.
- The IV&V contract must provide specific analysis and testing functions appropriate for the evolutionary development of EOSDIS.

Late this fall, NASA plans to begin other procurements related to EOSDIS:

EDOS, EOS Data and Operations System, to bring data from the EOS satellites and deliver Level 0 data to ECS;

ECOM, EOS Communications, to establish networks, especially for operational delivery of spacecraft data;

IV&V, Independent Verification and Validation.

We are particularly worried about networks, both for connecting investigators to the DAACs and for interconnection among investigators. We no longer view physical media as the "normal" mode of delivering data to scientists.

We recommend that the IV&V contract provide specific analysis and testing functions appropriate for the evolutionary development of EOSDIS to assure that the design of the system fully and correctly implements the requirements, that evolutionary changes are implemented consistently and correctly to best meet the scientists' needs, and that costly redesigns are avoided.

### *Data Assimilation in EOSDIS*

The EOS IWG and the broader science community must evaluate the scientific requirements for assimilated data available through EOSDIS, so that the processing loads can be accommodated.

The computational requirements for data assimilation (production of level 4 data products) are huge. It is not now possible to define the computing requirements precisely, because of the need to define the demand for assimilated data products and their quality specifi-

cations. All these needs are evolving, and many of them are rapidly changing disciplines of research and development.

The research-quality data sets that are needed for NASA Earth science applications require a level of internal physical and chemical consistency that is far beyond that achieved in present-day data

products used for numerical weather prediction. The data sets are expected to be used for problems with time scales of years to decades, instead of hours to days. The data sets will be used for problems far more difficult than the problem of prediction. Furthermore, many more types of data (e.g., constituent, land-surface, and oceanic) will be assimilated. □

## *A New NOAA Bulletin ——— Earth System Monitor*

An information bulletin called the "Earth System Monitor" is being produced by NOAA's Environmental Information Services office and is available free to requesters. Published quarterly, the monitor reports on NOAA programs, projects, and activities related to environmental data and information management.

Topics of recent articles have included planning for a major upgrade of NOAA's data management system; the "1800s forts" data base, a file of 19th century weather records digitized from old U.S. Army publications; applications of geographic information systems at NOAA's National Geophysical Data Center; and the Global Temperature-Salinity Pilot Project, an international effort to increase the quantity and quality of available ocean data. Each issue also provides information on new NOAA environmental data and information products and services such as CD-ROM data sets.

To receive a sample copy or to subscribe to the "Earth System Monitor," please contact:

Richard Abram  
National Oceanographic Data Center  
NOAA/NESDIS E/OC21  
1825 Connecticut Avenue NW  
Washington, DC 20235

Telephone: (202) 606-4561  
Fax: (202) 606-4586  
Omnet: NODC.WDCA  
Internet: services@nodc2.nodc.noaa.gov



## SAGE III Science Team Meeting

—*Bill Chu*

June 15 and 16, 1992, Omni Hotel, Newport News, Virginia.

The meeting was called to order by Patrick McCormick, NASA Langley Research Center (LaRC), the principal investigator, who reviewed the agenda and outlined the meeting objectives. Current activities relative to potential flight opportunities for SAGE III were discussed, as was the NASA Red Team/Blue Team concept and its potential impact on EOS.

Jack Kaye, the SAGE III Program Discipline Scientist at NASA Headquarters, reviewed the project status from a Headquarters perspective. He described his research and technology program, the budget constraints he faces, and the climate for future financial support for the SAGE III Science Team. Ed Mauldin, the SAGE III Project Manager LaRC, reviewed the project status by reiterating the calendar of events and explaining that the project is still in an extended Phase B mode. Spectrometer simplifications and CCD array design and development were covered in detail, as were improvements in instrument dynamic range and spectral performance.

Mauldin highlighted those areas where risk had been reduced and where performance margins had been increased during this extended Phase B period (i.e., using only 1st order dispersion on the holographic grating and eliminating the spectral flattening filter). He also said that the instrument could be delivered in less than 3 years from start of Phase C/D. Obie Bradley, the SAGE III Instrument Manager, outlined the instrument parameters and the improvements over the SAGE II instrument. He described the optics changes since CDCR and discussed the detector changes which have been incorporated to date. Grating issues were discussed, radiation shielding requirements were defined, and radiation shielding test results were highlighted.

Joseph Zawodny (LaRC) reviewed the highlights of the nitrogen dioxide retrieval workshop held in Boulder, Colorado, and described the latest results of studies of the SAGE III lunar occultation measurement capabilities. His discussion covered algorithm testing at the Boulder workshop and

showed that LaRC results agreed well with other algorithms at all wavelengths. Geoffrey Kent (Science and Technology Corporation) reviewed his 0.5-1  $\mu\text{m}$  aerosol/cloud extinction model and presented results obtained from the April 1991 SAGE II ground-truth mission, which showed good agreement between airborne lidar and SAGE II data. Kent's tropospheric aerosol analysis covered 7 years of springtime SAGE II data.

Bill Chu (LaRC) described his analyses for retrieving atmospheric temperature from solar occultation measurements of oxygen A-band spectra. The retrieval algorithm uses the emissivity growth approximation method. These measurements are key ones since they will make SAGE III independent of any external data source (e.g., NMC). Correlative measurement comparisons and constituent mixing ratio calculations will be greatly simplified. The retrievals described by Chu produced 1 km vertically-resolved profiles with < 2K errors between 6-60 km. The team remarked on the

importance of this self-calibrated measurement for important temperature trend data.

To begin the afternoon session, McCormick reviewed post-Pinatubo SAGE II aerosol data analyses, pointing out the papers included in the January 1992 issue of *Geophysical Research Letters*. He reviewed results from the May 1992 DC-8 mission to the Pacific, which covered latitudes from 37° N to 52° S, as well as the July 1991 mission to the Caribbean, both of which characterized the spatial distribution of Pinatubo aerosols. McCormick discussed the long-term stratospheric temperature from the Free University of Berlin, noting that the warming at 30 mb from Pinatubo aerosols had continued through February 1992. Zawodny described post-Pinatubo SAGE II NO<sub>2</sub> measurements, showing the very large global depletions near 25 km. Chu presented the latest comparisons of SAGE I and II ozone profiles with ozonesondes. Good agreement was found between the sondes and SAGE II measurements down to an altitude of 8 km. SAGE I/II trends were shown down to 15 km.

Er-Woon Chiou, Science Applications International Corporation (SAIC), reviewed recent SAGE II water vapor analysis papers, covering monthly zonal means, annual variations, and comparisons with LIMS and other data. Seven papers related to SAGE II water vapor data validation have been accepted for publication by the *Journal of Geophysical Research*. Mike Pitts (SAIC) described an analysis of SAM II aerosol data showing polar

stratospheric cloud (PSC) sighting frequencies and their correlation with temperature in both the Arctic and Antarctic. He also explained the total loss of data now being experienced in the Arctic, due to the Nimbus 7 orbit degradation, and the change in spatial coverage in the Antarctic.

The afternoon concluded with several reports from attending Science Team members. Derek Cunnold (Georgia Tech) described the importance of SAGE II ozone and NO<sub>2</sub> data in the analysis of MLS, ISAMS and other UARS data and outlined some of his comparisons. Jack Kaye suggested that SAGE II data also be compared with ATLAS data obtained on Shuttle flights. Peter Hobbs (University of Washington) then described aerosol programs underway on the international scene (e.g., IGAP) and on the national scene. He noted that the National Academy of Sciences is forming a panel on atmospheric aerosols under the Board on Atmospheric Sciences and Climate. The main charge of this panel will be to develop a report on the importance of aerosols on climate.

The meeting reconvened on Tuesday morning, June 16, with a continuation of reports from attending Science Team members. V. Ramaswamy (NOAA Geophysical Fluid Dynamics Laboratory, Princeton University) showed the radiative effects of ozone depletion derived from SAGE I and SAGE II data in the lower stratosphere. This loss of ozone results in decreased radiative forcing of the surface-troposphere system. Ramaswamy concluded that the net result of the increased radiative

forcing due to CFC build-up, and the decreased radiative forcing due to ozone gas cancelled each other at the high latitudes. John DeLuisi (NOAA Climate Monitoring and Diagnostics Laboratory) described his comparisons of SAGE II, SBUV, and Umkehr ozone measurements in layers 1 through 9, showing generally good agreement. Ben Herman (University of Arizona) described his spherical geometry radiative transfer models and the conical analysis used to retrieve constituents from limb scattering measurements. David Rind (NASA Goddard Institute for Space Studies) reviewed his work with SAGE II water vapor data and the effects of the Pinatubo eruption, and discussed the need for detailed comparison of frost point hygrometer and Lyman- $\alpha$  water vapor measurement techniques. He also showed SAGE II cloud analyses and described the recently produced movie illustrating SAM II and SAGE II aerosol measurements.

Ross Salawitch (representing Steve Wofsy of Harvard University) described recent ER-2 and balloon-borne measurements of ClO, N<sub>2</sub>O, HCl and NO<sub>2</sub> at 66° N collected to support photochemistry modeling studies and investigate the implications for ozone depletion from a mechanistic standpoint. He used SAGE II measurements to constrain modeling solutions, thereby demonstrating a very important potential use of SAGE III data. J. Lu (representing Volker Mohnen of State University of New York at Albany) outlined proposed efforts using SAGE II data to track the transport of aerosols and ozone into the free troposphere and delineate the stratospheric compo-

nent from the boundary layer component. Vin Saxena (N. C. State University) presented the results of a recent study on stratospheric aerosol size distribution during the 1987 Antarctic ozone depletion episode. Phil Russell (NASA Ames) described airborne measurements obtained using a tracking solar photometer and in situ measurements taken in conjunction with the DC-8 mission over the May 1992 Pacific. The data showed good agreement with ground-based lidar data obtained at Mauna Loa. Jacqueline Lenoble (University of Lille, France) showed a comparison of balloon-borne radiometric data with SAGE II data. Her aerosol size distribution retrievals showed good agreement with SAGE II retrievals as well as with lidar measurements. Lenoble also discussed plans for an intercomparison campaign for ultraviolet spectrometers to be conducted in Greece in the near future. Derek Montague (representing Gabor Vali, University of Wyoming) outlined two methods to be used to determine the global climatology of upper tropospheric clouds from SAGE aerosol data.

Pat McCormick concluded the meeting by presenting details on the Nimbus 7 and ERBS orbital degradation, which showed the data gap we are beginning to experience. A brief discussion was also held on building a prototype SAGE III instrument at Langley. The team felt that it was a good idea and that an airborne version, perhaps using the Ames tracking system, would be a wise addition. McCormick expressed his appreciation to the team for the hard work and accomplishments to date

and emphasized that the extended Phase B period had allowed for significant reduction in risk, which

should yield a superior scientific instrument that will meet schedule and cost constraints. □

## MISR Cloud Masking Workshop

—Daniel Wenkert, MISR Science Coordinator, Jet Propulsion Laboratory

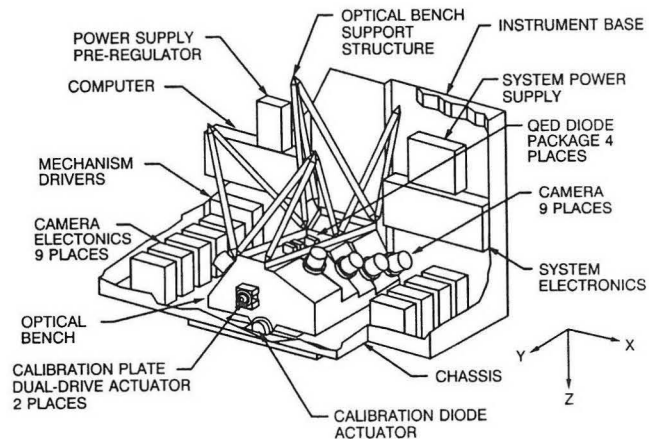

**T**echniques for identifying and masking clouds in image data were discussed by representatives of several EOS-AM experiment teams in Montreal, Quebec on August 17, 1992. This Cloud Masking Workshop was hosted by MISR Co-Investigator Roger Davies of McGill University and coincided with the first day of the 11th International Conference on Clouds and Precipitation. Representatives of the MISR, MODIS, CERES, and MOPITT experiments attended, along with the EOS-AM Project Scientist, Bruce Guenther.

The goals of the workshop were to discuss progress in developing cloud-masking techniques to be

applied to MISR data, to make a preliminary decision on what will constitute the MISR Level 1 cloud mask, and to outline plans for cloud masking at Level 2. Davies began the workshop by pointing out the difference between "primitive" cloud-masking routines and more sophisticated cloud classification schemes. Primitive cloud masking is used to determine the location of clear-sky pixels for analysis of the non-cloud properties of the target. More-sophisticated schemes are used for the scientific investigation of clouds. Davies noted that primitive cloud masks (1) could be used to identify clear-sky regions for MISR image navigation, (2) can be conservative ("when in doubt,



throw it out”), (3) must be fast and objective, perhaps involving one or two simple thresholds, and (4) must be derived individually for each of the nine MISR cameras due to cloud altitude causing the boundaries of clouds to appear at different locations in images acquired at different angles.

Ken Jones of the JPL MISR Data System Team then discussed EOS-AM navigation issues and their implications for generation of MISR Level 1 products. Based upon the MISR team’s understanding of the potential platform pointing and positioning capabilities, previous plans for routine optical navigation using ground control imagery have been dropped in favor of a “dead reckoning” approach. Optical navigation would be required only in a limited way early in, and periodically throughout, the mission to geometrically calibrate the MISR cameras and to remove static pointing biases. John Barker of GSFC mentioned that MODIS has similar requirements.

Larry Di Girolamo of McGill presented some concepts for primitive cloud masking. For ocean scenes, he has developed a thresholding technique involving 865-nm data from the MISR cameras. Over land, he would use the average reflectance from all four of MISR’s spectral channels, the variance of that reflectance, and a vegetation index similar to NDVI as a clear-sky detector. Di Girolamo felt that this method should work over most land surfaces, except snow. MISR Co-Investigator Peter Muller of University College London stated that he would only use data from

snow-free seasons in developing the global elevation model he plans to generate using MISR high-resolution data.

Muller described two cloud detection techniques he has used on AVHRR data. The APOLLO cloud detection scheme, a multi-band threshold technique, was developed by the UK Meteorological Office. Another scheme relies on arithmetic differences between brightnesses in two images of the same region. Using a large sample of input images, a reference image of cloud-free pixels is built up of a specific geographic region for a specific season. Muller compared the results of cloud masks derived for some AVHRR images of tropical forest in Rondonia state in Brazil, using the APOLLO and picture-differencing techniques. The latter scheme was superior for detecting small scattered cumulus clouds, which he felt constituted the most difficult cloud detection problem in that region. Since no MISR cloud-free reference images would be available at launch, Muller suggested using cloud-free images based on ERS-1 ATSR data, until a large-enough MISR data base existed.

MISR Co-Investigator, Tom Ackerman of Pennsylvania State University, stated his need for a cloud detection algorithm that could successfully distinguish between a pixel that was aerosol-rich and one that was somewhat cloud-covered, before aerosol retrievals are performed in Level 2 processing. He described initial results on cloud identification using two-dimensional histograms of radiances and band-differenced radiances in AVIRIS imagery at the MISR wavelengths. Eugene

Clothiaux of Penn State then discussed the possibility of training a neural network to recognize clouds, based on the experience of human image classifiers who recognize clouds by eye. His proposal is to have trained humans to identify the cloudy pixels in a set of training images, and to use this as input to the neural net. By doing this repeatedly with a large number of different cloudy scenes under a variety of conditions, the neural net should become capable of automatically identifying cloudy pixels. Ron Welch (of the ASTER team) and other investigators have already done a lot of this work manually. Clothiaux suggested that after a neural net had been trained to correctly identify cloudy pixels under a wide variety of conditions, the identification criteria which the net had automatically developed could then be used in a numerical cloud classification algorithm.

John Barker described the MODIS texture and masking algorithms. These should produce two different MODIS products. The texture product, derived from MODIS’s two 250-m spatial resolution bands, will include a spatial heterogeneity (texture) image and a single-bit pure pixel binary mask. The classification overlay image should produce a yes, no, or maybe answer for eight categories of scene in each pixel: cloud, snow and ice, water, land, image terminator, sun glint, vegetation, and shadow. Barker also discussed simulations of MODIS data using data from Landsat’s Thematic Mapper. In a cloudy and snowy image of the Chugach Mountains in Alaska, he showed the importance of TM’s 1.6 micron band in

distinguishing between clouds and snow. However, Barker felt that thermal infrared data were needed to do an even better job. The old classification scheme for TM data uses simple thresholds in the visible, shortwave infrared, and thermal infrared regions of the electromagnetic spectrum. Barker felt that MODIS will probably use cluster analysis (rather than simple thresholds) for better classification, to help identify pixels having mixed scenes.

After lunch, MISR Principal Investigator, Dave Diner of JPL, asked what the MISR team wanted the Level 1 cloud mask to accomplish. Graham Bothwell, MISR Science Data System Manager from JPL, displayed a chart on MISR Level 1 processing that was prepared for the previous MISR science team meeting in February 1992 and discussed possible modifications to that chart. At the end of discussion by the entire group, it was agreed that McGill would have primary responsibility for developing the Level 1 cloud masking algorithm. Its purpose would be the unambiguous detection of clear sky. Diner summarized the results for MISR Level 1 products:

- (1) Radiometrically-corrected non-resampled MISR data will be generated as the Level 1B1 product. This will have primitive, low-spatial-resolution cloud masks appended. Nine cloud masks are generated at Level 1, one for each of MISR's cameras, at 2.2-km resolution (8x8 averaging of MISR's fundamental 275-m spatial resolution).

- (2) Level 1B1 data will then be resampled and projected on a simple reference surface, without regard to topographic effects. The result would constitute the Level 1B2 product.
- (3) The Level 1B1 data will also be resampled and projected onto a digital elevation model for all land areas, regardless of the cloud mask. The result would constitute the Level 1B3 product.

Each Level 1 product will have a specific purpose. Jones expects to use the Level 1 cloud mask to ensure suitable ground control imagery for camera geometric calibration. Muller will use MISR Level 1B1 data as input for deriving digital surface and cloud elevation products. Davies needs MISR Level 1B2 data to produce a variety of climatological products; specifically, he pointed out that top-of-atmosphere albedo could be generated directly from such data. MISR Level 1B3 data will be used for surface BRDF and aerosol retrievals over land; Ackerman and JPL Co-Investigator John Martonchik will need a sophisticated Level 2 cloud mask as input to the algorithm for producing these surface-projected data.

Participants discussed which reference altitude should be used for the Level 1B2 image projection. Jones proposed using a Space Oblique Mercator projection to provide maximum flexibility in this regard. The SOM projection uses coordinates that are centered around the spacecraft orbit, rather than being fixed to the Earth's surface. In this projection, objects

at a given altitude above the Earth's surface can be brought to the same point in images taken at the different angles of MISR's cameras by sliding the images along each other in the direction of spacecraft flight. Different amounts of sliding are needed for different altitudes of the object being observed. The consensus of the meeting was that SOM is a good candidate for the Level 1B2 product.

MISR Science Coordinator Daniel Wenkert of JPL then presented the latest instrument operating scenario, in which data from any 14 of MISR's 36 channels (camera and spectral band combinations) are recorded at full (275-m) resolution and data from all other channels are averaged either 8x8 or 4x4 and recorded at the resulting 2.2-km or 1.1-km resolution. Various opinions were expressed regarding the optimal channels for recording full-resolution data for high-fidelity cloud identification. In particular, the merits of concentrating the high-resolution observations on all spectral bands of a few cameras versus distributing them among all nine cameras in a limited number of bands were debated. Further work on the Level 2 cloud masks should help elucidate this issue. Diner asked if anyone wanted to compromise and use data recorded after 2x2 averaging (i.e., at 550-m resolution). Several team members responded in highly negative non-verbal fashions!

Two presentations on recent MISR-related cloud studies were given. Tamas Varnai of McGill described his work on deriving the BRDF of a cloud field from incomplete

MISR-like angular sampling. He has been investigating two techniques: (1) deriving mathematical relationships between a few individual radiances and complete BRDFs, and (2) using full physical models of clouds. Next, Di Girolamo spoke about Band-Differenced Angular Signature (BDAS) techniques. He presented the results of a large number of simulations using the functional dependence of the difference in radiance between two spectral bands on viewing and illumination angles in order to determine minimum-detectable cloud vertical optical thickness.

Davies suggested that since most of the cloud-masking computational burden has now been moved from Level 1 processing of MISR data to Level 2, all data sources should be considered, including MODIS. Whether non-MISR sources are desirable will be determined from further research on the MISR Level 2 masks.

Bothwell pointed out that the beta-version of MISR's product generation software was due to be delivered to the LaRC DAAC in 1995. Moreover, Bothwell and the ESDIS project need to know something about these algorithms this year. It was agreed that Di Girolamo's BDAS technique, Muller's picture-differencing algorithm, and Clothiaux's neural net scheme were all possibilities for the Level 2 cloud classification algorithm. These techniques will be discussed further at the next meeting of the full MISR Science Team. □

## Infrared Calibration Symposium at Utah State University

An infrared calibration symposium for radiometric sensors was held at Utah State University in Logan, Utah from September 14-17, 1992. Symposium leaders and participants included more than 150 representatives of academia, NIST, DoD, DoE, associated support contractors, and, for the first time in the three years the symposium has been meeting, NASA, and NASA support contractors. The NASA remote sensing community was warmly welcomed to the symposium, and the NASA presence seemed to provide a "critical mass" that brought out the best efforts of speakers and other participants.

The symposium included both formal presentations and informal poster sessions. Speakers at the formal sessions were invited, and presentations were generally tutorial in nature. First-day sessions included presentations by representatives of NASA/ EOS, NOAA, ARM, SDIO, and DoD, and included discussions of specific agency programs and associated sensor calibration requirements and activities. Vince Salomonson, Director of the Earth Sciences Directorate at NASA/ GSFC, discussed the EOS program, MODIS, and MODIS calibration in the first lecture of this series. Second-day sessions

included tutorials on infrared radiometry, spectral response, and spatial response. The third day was dedicated to on-orbit infrared calibration and lessons learned from previous programs.

NIST and the physical standards community were well represented in the poster sessions, as was the terrestrial standards community. "Ground truth" radiation sensed for selected terrestrial reference targets will serve as a standard for on-orbit remote sensor calibration. Poster sessions included material on alternative terrestrial measurement techniques and comparisons of results. NIST is rebuilding its thermal vacuum calibration capabilities, and the poster sessions provided ample opportunity for direct interactions with the researchers involved.

The last day of the symposium was dedicated to a "peer review" of EOS infrared sensor calibration requirements, and included presentations on the calibration of CERES, MODIS, ASTER, AIRS, and MOPITT. Comment forms were distributed to the audience, and attendees were asked to provide comments and reactions to the EOS calibration plans.

— Al McKay  
Research and Data Systems Corp.



## Volcanology IDS Team meets at Goddard Space Flight Center for Eruption Plume Meeting

IDS Volcanology Team Meeting held July, 1992 at Goddard Space Flight Center  
—Pete Mouginis-Mark (Univ. Hawaii), IDS Volcanology Leader

Continuing the efforts to perform scientific investigations of explosive volcanic eruptions and develop algorithms for EOS instruments, members of the EOS IDS Volcanology Team held their latest meeting at NASA/Goddard Space Flight Center July 23-24. The meeting was hosted by Lou Walter and Arlin Krueger. In addition to the outstanding opportunities for satellite analyses of eruption plume growth and the stratospheric dispersal of volcanic aerosols provided by the June 1991 Pinatubo eruption, other eruptions and volcanic processes also were discussed over the two days. The meeting also was fortunate to have two representatives from the AM-1 platform in attendance to provide information on the mission operations of the first EOS spacecraft.

Much of the meeting focused on the physics and dynamics of eruption plumes, and the algorithms and data sets that will be developed for the EOS era. Particularly important in the context of climate change, eruption plumes provide the direct link between the geology of the volcano, the injection of material into the stratosphere, and short-term (1 - 3 year) climate change. As observed at Pinatubo, as much as 20 ktonnes of sulfur dioxide can be injected into

the stratosphere by an eruption. Furthermore, more than a year after the Pinatubo eruption these aerosols are still affecting stratospheric chemistry and surface weather.

In the context of plume transport of gases and particulates, Steve Baloga (JPL/NASA HQ) and Lori Glaze (JPL/Lancaster University) discussed their current efforts to model the dynamics and thermal mixing of eruption plumes. Since images exist of the turbulent nature of plumes on which to base these models, high-spatial-resolution visible/near-IR data from ASTER and the potential HIRIS-2 instrument were identified as important future data sets for the analysis of plume morphology.

In a related presentation on plume structure, Lionel Wilson (Lancaster University, England) discussed the new algorithms that he is developing for the determination of the topography and height of eruption plumes using AVHRR LAC images. Plume height is a critical parameter for understanding the energy of the plume and will be obtained from the AM-1 platform from stereo ASTER and MISR data. Wilson's technique uses the visible (0.4 - 0.9  $\mu\text{m}$ ) photometric properties of the plume as well as the geometry of the plume shad-

ows to determine the height and the structure of the plume. Through the comparison of the spatial variations in plume topography and temperature (measured in the thermal infrared (10.4 - 12.4  $\mu\text{m}$ ) from the AVHRR data) the buoyancy and rate of release of thermal energy from particles entrained within the plume can be investigated.

Rick Holasek and Steve Self (University of Hawaii), and Dave Schneider and Bill Rose (Michigan Technological University), also reported on the use of AVHRR data for eruption plumes, this time as an analog for MODIS measurements. In this instance, the development of algorithms for the automatic detection of explosive eruption plumes with MODIS forms the primary method by which the Volcanology Team will detect new eruptions in remote locations that might otherwise go unreported on the ground. Using AVHRR scenes of the eruptions of Pinatubo (1991), Redoubt (1989/1990) and Mt. St. Augustine (1986), these investigators are working on the detection of eruption plumes based on their spectral and thermal characteristics.

A significant step in the Team's plans for the analysis of plumes was the identification of field

strategies for the collection of airborne and field data that might help in the development of measurement plans for EOS. Currently being planned by Dave Pieri, JPL, is a 1993 field campaign to study the volcanoes in Kamchatka, Russia, where several very large volcanoes continue to have mild activity and threaten major eruptions of the Pinatubo class. Detailed measurements of the spatial distribution of volcanic gases in a plume—particularly SO<sub>2</sub> and HCl—have to be collected, since no quantitative information currently exists on the rate of release of these gases. Comparable EOS data will be available from TES, MLS, and AIRS, but these will lack the spatial resolution to interpret the dynamics of the rising plume. Thus planning is underway for using a COSPEC (a UV instrument) and other spectrometers (operating in the mid-infrared) in Kamchatka to correlate the gas released from individual vents with the visible characteristics of the eruption plume.

EOS observations of volcanic gases were described by Joy Crisp (JPL), who has been modeling the ability of MODIS, AIRS, and TES to make routine spectral observations of volcanic gases. So little is known about the volatile budgets of many of the world's volcanoes that baseline information on the natural sources of volcanic gases is expected to come from MODIS, AIRS, and TES. Further data on the amount and distribution of volcanic aerosols will also be collected by MISR and SAGE II/III. In the case of aerosols released by recent large eruptions, considerable information has been collected by the Total Ozone

Mapping Spectrometer (TOMS). Arlin Krueger, Lou Walter, and their colleagues at Goddard reviewed the TOMS data set, which shows the amount of sulfur dioxide released by large eruptions over the last 13 years. The TOMS data, in addition to providing insights into the temporal evolution of the gas released from these eruptions, also give insights into the sulfur budget of volcanoes in different tectonic settings. In this

---

**“A significant step in the Team’s plans for the analysis of plumes was the identification of field strategies for the collection of airborne and field data that might help in the development of measurement plans for EOS.”**

---

way, major Solid Earth processes such as mountain building are being linked to latitudinal variations in volcanic inputs into the atmosphere. A further aspect of the TOMS data analysis is that these data are providing valuable experience in the near-real-time interpretation of satellite data sets, and this will be important when the Volcanology Team is searching the MODIS thermal IR data stream to identify new eruptions.

Ed Chang and Bruce Guenther attended the second morning of the Team meeting in order to discuss mission operations and

data volume issues on the AM-1 platform. Much of the discussion focused on the collection of ASTER data, which will be critical for many observations of eruption plumes and active lava flows. The pointing capabilities, duty cycle, and speed with which ASTER can observe a specific target on the Earth are all important to the Volcanology Team. Obviously, volcanic eruptions are transient phenomena, so measurements from EOS (and ASTER in particular) have to be obtained as quickly as possible in order to observe the processes while they are changing. There may be as many as six eruptions each year that will need frequent observations by ASTER for more than a month, with the first images obtained within 1 - 2 days of the onset of the eruption. Such constraints not only place heavy demands on the use of ASTER, but also demonstrate the need for the early automatic detection of volcanic activity by MODIS on either the AM or PM platforms.

Although explosive eruptions formed the focus of the Goddard Volcanology Meeting, other aspects of volcanism and its effects on the atmosphere are also being investigated by the IDS Volcanology Team. In particular, new nighttime spectroradiometer measurements of active lava flows and lava lakes are being used to develop algorithms for ASTER and MODIS. For example, it will be necessary to investigate lava flows at temperatures in excess of 500° C, so algorithms are being developed to derive the temperatures of targets at the sub-pixel scale. Topographic analyses, using digital elevation models (DEMs)

generated by radar interferometric techniques, also are being used to model and interpret volcanic processes. These DEMs are being used as precursors to the data sets to be produced by stereo measurements that will be made by ASTER and MISR. It is expected that the investigation of lava flow thermal properties and the topographic investigations will form the primary focus of the next IDS Team meeting.

Members of the EOS community who want to learn more about the science rationale and the specific EOS instruments that will be used for the IDS Volcanology investigation also might like to see the following two recent articles. (Copies of the articles can also be obtained from Pete Mougini-Mark, Planetary Geosciences, 2525 Correa Road, Honolulu, HI 96822.)

Mougini-Mark, P.J. and 18 others (1991). *Remote Sensing of Environment*, 36, 1 - 12.

Mougini-Mark, P.J. and P.W. Francis (1992). Satellite observations of active volcanoes: Prospects for the 1990s. *EPISODES*, 15, 46 - 55. □

## New Tools for Working With Spatially Non-Uniformly-Sampled Data from Satellites

—Andrew Pursch, Ralph Kahn, Robert Haskins, and Stephanie Granger-Gallegos  
Jet Propulsion Laboratory, California Institute of Technology

### Introduction

NASA's Earth Observing System (EOS) will generate vast quantities of data. Hundreds of terabytes of data will be acquired from orbit to characterize the Earth's environment with the kind of spatial and temporal detail needed to study climate change. It is also expected that the data will be analyzed not just in the traditional manner, concentrating on a single data set at a time, but in new ways that involve routinely comparing data sets from multiple sources.

This article describes methods we are developing to address several specific aspects of such analysis. Our application involves the analysis of parameters derived from the High Resolution Infrared Sounder 2 (HIRS2) and the Microwave Sounding Unit (MSU) instruments aboard the NOAA polar orbiting meteorological satellites using a physical retrieval algorithm (Susskind et al., 1983; 1984). These instruments provide one of the few global measures of cloud properties and related environmental parameters extending over many years. We are interested in making as much use as is possible of the HIRS2/MSU data to constrain the

cloud/climate feedback parameterization in the Goddard Institute for Space Studies (GISS) climate model. To do so, we must first validate the observations. By "validation" we mean "developing a quantitative sense for the physical meaning of the measured parameters," for the range of conditions under which they are acquired. Our approach involves: (1) identifying the assumptions made in deriving parameters from the measured radiances, (2) testing the input data and derived parameters for statistical error, sensitivity, and internal consistency, and (3) comparing with similar parameters obtained from other sources using other techniques (Kahn et al., 1990).

In the process of meeting our primary objective, we also are learning about analyzing large geophysical data sets in general (e.g., Granger-Gallegos, et al., 1992). We present here some of the techniques we are developing to identify and study geographical regions where a 2-dimensionally-distributed parameter (such as surface temperature) is well-sampled, in a statistical sense. We begin by discussing the need for a

more-detailed approach to characterizing a spatially non-uniformly-sampled parameter than simple gridding and averaging. The subsequent section describes a tool, currently in development, that makes it possible to view and select point data from a large data set based upon criteria set by a user-selected combination of point-data (Level 2) and gridded-data (Level 3) conditions. The paper concludes with an explanation of Image/Vector Files, a file structure we developed to make this kind of data analysis possible.

### **The Need for Both Level 3 and Level 2 Data**

The most manageable and widely-distributed form of the HIRS2/MSU physical retrieval parameters is the monthly mean product, gridded on a 2 by 2.5 degree latitude-longitude grid (Level 3 data). Level 3 data are easily displayed as images, making them useful for obtaining a qualitative, global view of the behavior of a parameter. Regions where a parameter has sharp gradients, or where it is relatively uniform, can be identified.

We found several problems with only using these "spatially uniform," relatively low-volume, Level 3 products for quantitative work. An example of one of these problems is given in Figure 1. Figure 1 shows how artifacts as large as the original signal are introduced when a monthly mean product on a 2 by 2.5 degree grid is re-gridded to 500 by 500 km bins that happen to be the standard for a comparison data set. A second problem with the Level 3 data is that the binned product does not

contain information about how much of the reported variance is due to inherent non-uniformity of the parameter over the averaging region. For example, in a 2 by 2.5 degree box, the surface temperature may exhibit random fluctuations of half a degree and may change systematically by several degrees, whereas the box average variance will assign all the variability to random error.

In order to make meaningful interpretations of non-uniformly-sampled data, the data must be handled on a regional basis. We select regions for study based upon statistical criteria, such as measures of the degree to which a parameter of interest is well-sampled by the observations. In the selected region, surfaces may then be fit to the data and variance surface calculated, with the assurance that the behavior of the underlying field is as well-represented as the satellite observations will allow. These are the first steps in making a comparison between spatially non-uniformly-sampled observations of, for example, cloud amount, from two sources.

Such procedures require us to work with both Level 3, and the larger-volume Level 2 data. Level 2 data sets for the HIRS2/MSU physical retrievals (about 25 MB per day), are comprised of individual soundings. With the Level 2 data, there are gores at low latitudes in the HIRS2 sampling between orbits, whereas at high latitudes, the surface is heavily oversampled. Data dropouts and calibration lines occur at all latitudes. The sample resolution changes by more than a factor of 2 from nadir to the limits of each scan.

In summary, the binned field provides a global, qualitative view of the data. From this global view, regions of interest can be selected, based upon the behavior of the Level 2 data. Once a region of interest is identified, locally adaptive surface fitting and other techniques are applied to the Level 2 data. The next section describes software we are developing to make it feasible to perform such operations with large data sets like those from the HIRS2/MSU.

### **Widget-based Interactive Geographic Subset Selection (WIGSS)**

We are developing Widget-based Interactive Geographic Subset Selection (WIGSS) as a practical tool that allows us to study geographic sub-regions of a global data set. WIGSS makes simultaneous use of Level 3 (gridded) data and Level 2 (point) data. The Level 3 data offer an overview of the distribution of parameter values, which can be displayed using gray-scale or color, mapped to the range of the parameter values. The Level 2 data contain the precise locations and parameter values at the points where the instrument measurements were taken.

WIGSS can be used, for example, to locate well-sampled regions for statistical characterization of a parameter, and for comparison with other parameters. The desired condition might be that the gradient in parameter value be small, in some formal sense, relative to the physical spacing of the measurements. The program allows the user to make such determinations for any sub-region, to perform operations such as



Figure 1.

The Effect of Rebinning on Global Cloud Amount. Figure 1a shows the original HIRS2/MSU monthly mean cloud amount product, on the standard 2 by 2.5 degree grid, for July, 1979. Figure 1b shows the same data, regridded to the Earth Radiation Budget Experiment (ERBE) standard 500 by 500 km grid using bi-linear interpolation. Figure 1c shows the difference field, formed by taking the data from 1b, gridding it back to the HIRS2/MSU standard using bi-linear interpolation, and subtracting it from the data in Figure 1a. If the gridding operation itself did not affect the results, Figure 1c would be flat grey.

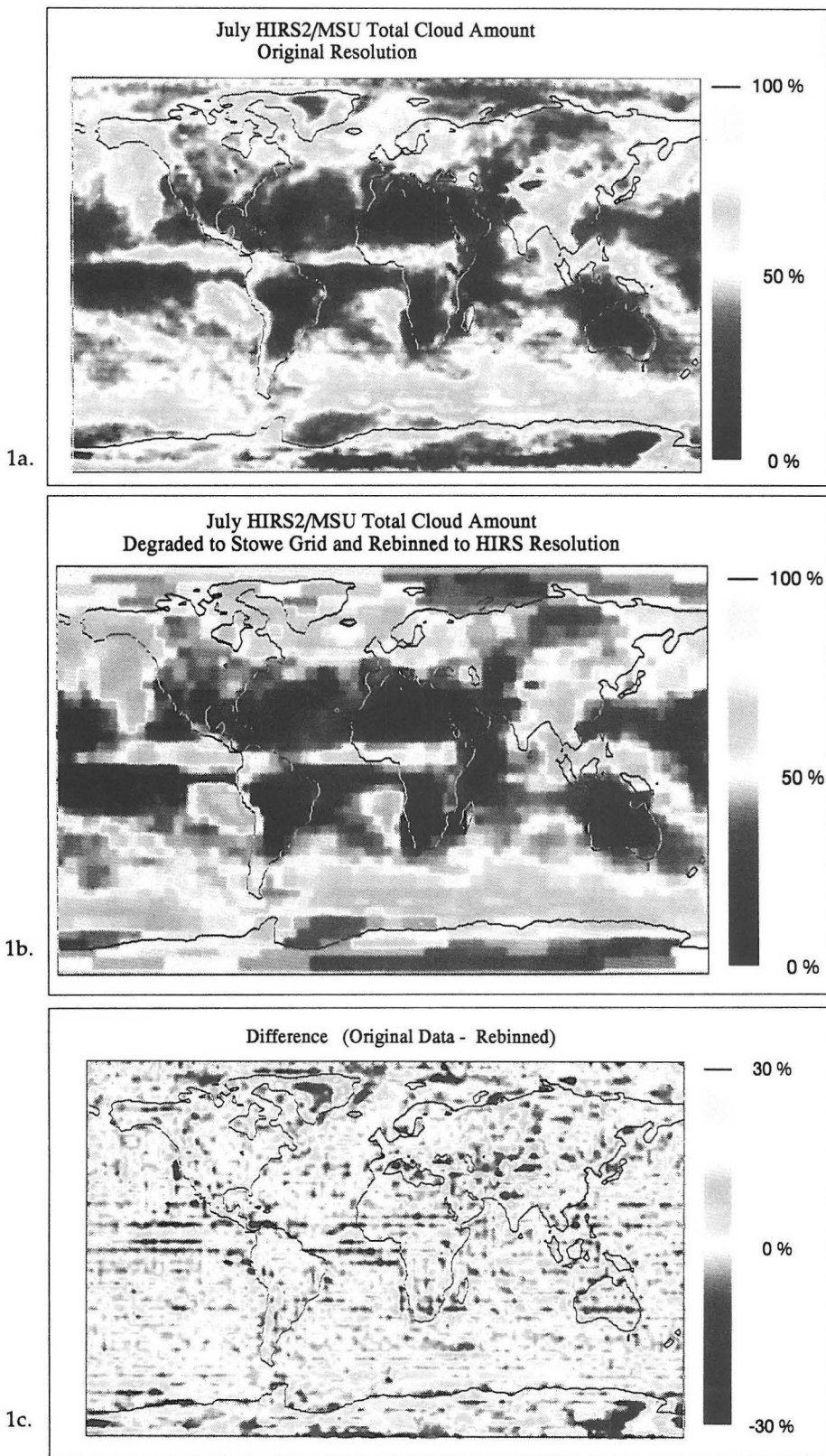

Figure 1

surface fitting to the selected data, and to create files of the Level 2 data from the sub-region for further analysis and intercomparison. WIGSS is being written with the Interactive Data Language (IDL) package, using their new widget features as the foundation of the design.

The user interface is shown in Figure 2. At startup, WIGSS displays the main screen (parent widget) from which all further interaction takes place during the WIGSS session. The parent widget consists of a control panel with 7 pull-down menus, positioned

above six windows arranged in two columns of three, and a command window across the bottom of the screen. Level 3 data are shown in the lower left window. When requested, the locations of points in Level 2 data are displayed in the middle right box, together with superposed contours of the associated parameter values. Also the numerical values of Level 2 data points may be displayed in the upper left window. Thus, on a single screen, the user can study individual point data in the context of the entire global distribution of parameter values.

A typical session may go in the following manner: The user selects a data file to study. From this file, the user selects a parameter, and the gridded Level 3 data are displayed. Features in the data can be enhanced by applying any of the color palettes that are available. Once this is done, a subset of the gridded data can be chosen by outlining it with a box. This "box subset" can now be studied in detail by viewing the display of Level 2 points that were used to generate the selected subset of the gridded image. Sampling and other characteristics of the original observations may be seen in the

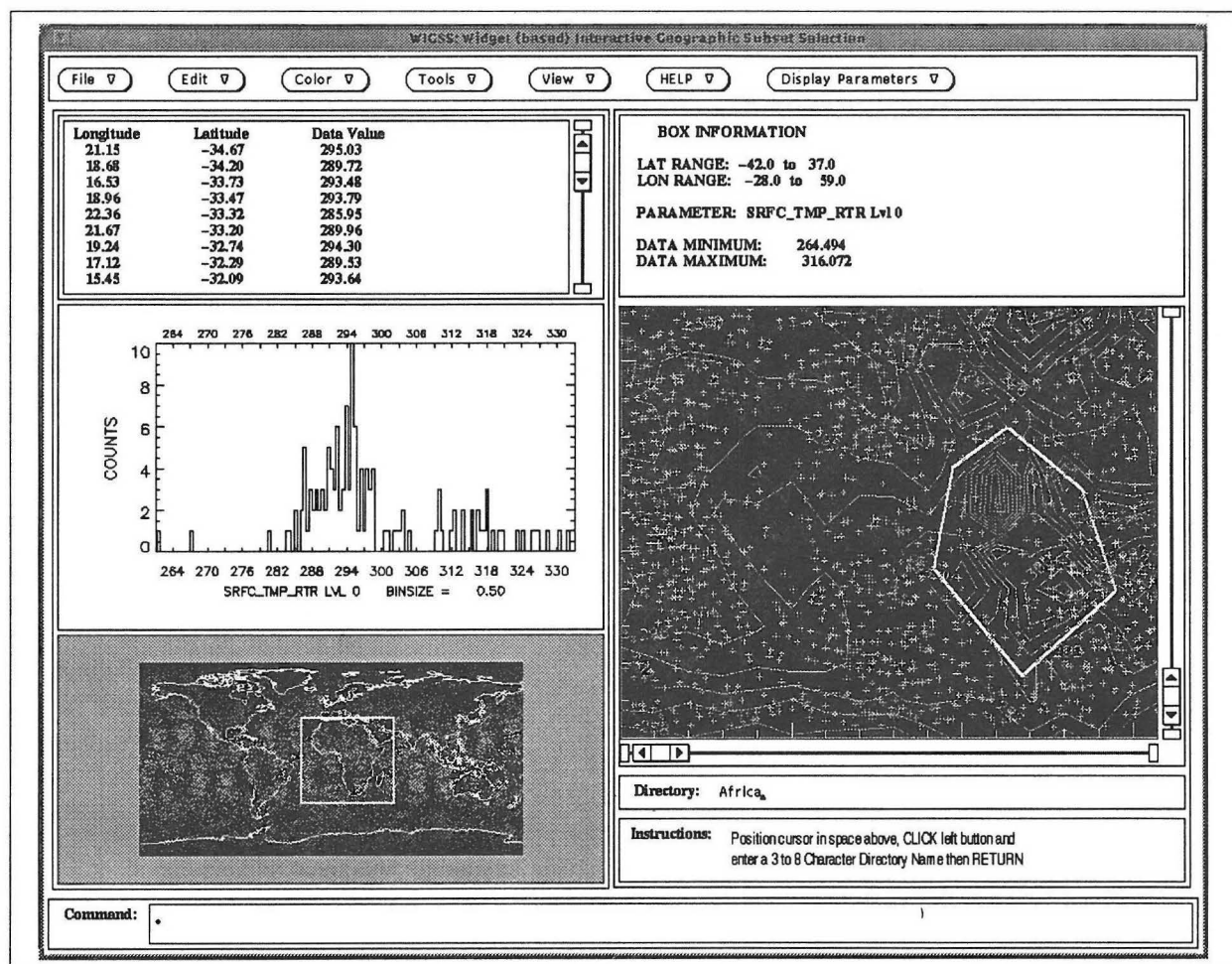

Figure 2. The Widget-Based Interactive Geographic Subset Selection (WIGSS) user interface.

Level 2 display. Any region within the Level 2 display window can now be selected for further study, by identifying the area of interest with a mouse-drawn outline of any shape.

The analysis tools within WIGSS operate on the subset of the Level 2 display. These include several types of surface fitting, histogram and variogram displays. If desired, the Level 2 data associated with the selected geographic subset can be written to a standard Hierarchical Data Format (HDF) file and/or to an ASCII tabular file. The box subset and region subset information are saved along with a session log so that complete reproducibility is possible. A list of all the operations in the current version of WIGSS is given in Figure 3.

A number of tools under development include:

1. Contour Plot, to contour selected Level 2 or derived data points
2. Surface Plot, which is used in surface fitting of Level 2 or derived data points. Surface plots require that the data be on a regular grid. We currently have a choice of Delauney Triangulation and Modified Shepard's algorithms available for interpolating our irregularly-spaced data to the grid
3. Sliding window statistics, which provides a means of making statistical calculations on the data that fall within a window as they are passed over the grid

4. Data manipulation through the use of arithmetic operators (adding data, differencing data, applying scales and offsets, etc.)
5. Point data editing, which allows for the removal of erroneous data
6. Advanced statistical calculations that characterize key attributes of the data. These may include the characterization of sample spacing, the characterization of spacing vs. gradient of the parameter value, and the measures of heterogeneity
7. Thermodynamics, which derives various thermodynamic properties of the data

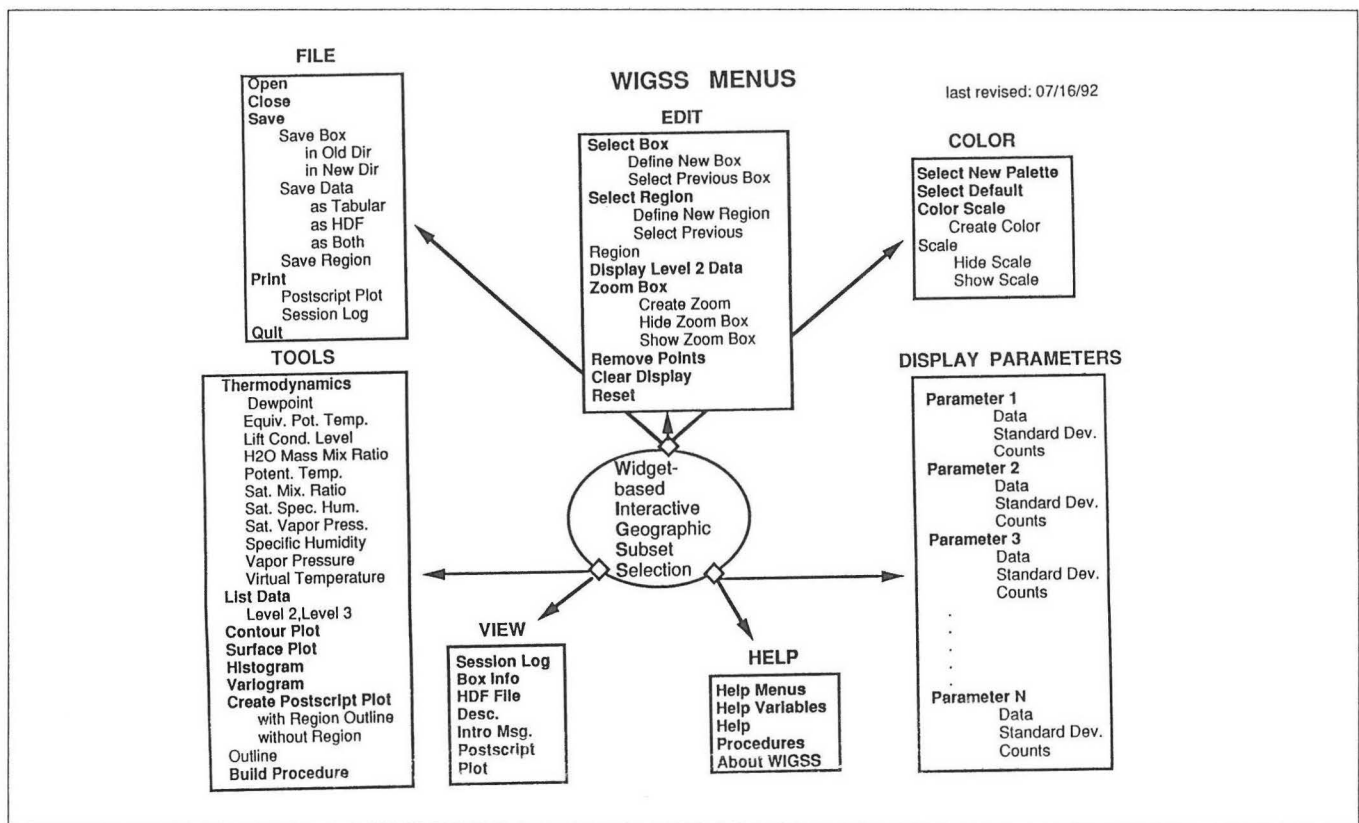

Figure 3. Entries in the WIGSS Menus, indicating the current functionality of this software.

8. Build Procedure, which allows, through the use of the command window, the user familiar with IDL to build new IDL procedures to interact with the WIGSS environment.

### Image/Vector Files

To support a tool like WIGSS, we needed an underlying file structure that contains the Level 3 data, the associated Level 2 data, and information describing the connections between the entries in the two. This function is served by Image/Vector files. Image/Vector files take advantage of features found in the Hierarchical Data Format (HDF), a transportable file format developed by the National Center for Supercomputing

Applications (NCSA) at the University of Illinois.

An Image/Vector file, as the name implies, consists of images of Level 3 data along with vectors of associated Level 2 data. Three gridded fields contain images of:

- (a) the Level 3 data.
- (b) standard deviation calculated for the entries in each grid box.
- (c) counts of the number of soundings that fall in each grid box.

The images are stored as HDF scientific data sets (SDSs). Four vectors consist of:

- (a) the "connectivity list" (see below).
- (b) all the Level 2 point data.

- (c) the latitude and longitude of each sounding.
- (d) a time tag.

The information is stored as HDF Vset vector data (VDATA) (see Figure 4).

The key element of an Image/Vector file is the connectivity list (clist), which 'connects' the gridded fields to the vectors of individual points. The clist contains four elements for each cell of the grid (Figure 5). These elements contain the reference latitude and longitude for the grid cell, an index to the VDATA for the cell, and a count of the number of Level 2 reports that fall into the cell.

Access to a VDATA is accomplished by converting the row and

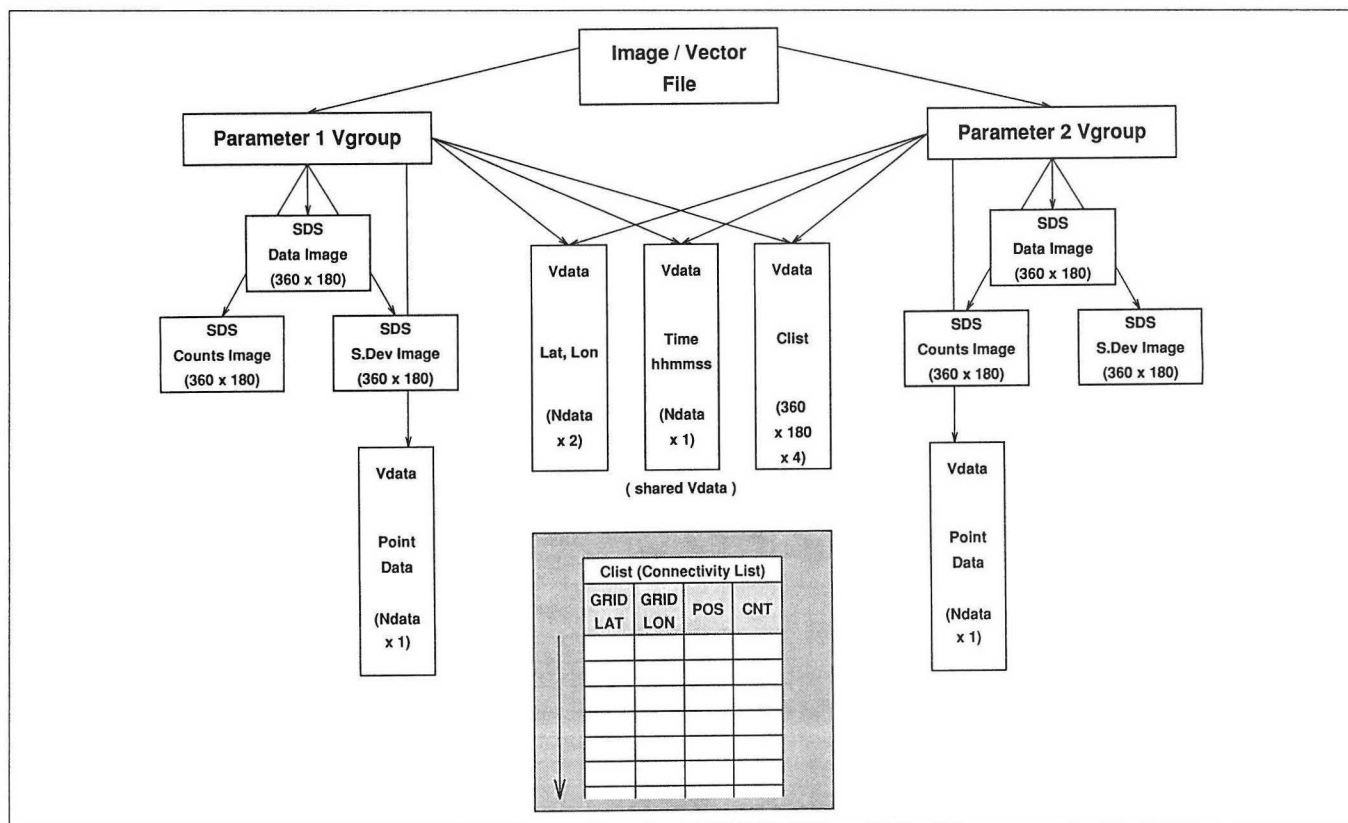

Figure 4. The Structure of an Image/Vector File.



column of the point of interest to a grid cell number. The grid cell number is used as an offset into the clist to retrieve the reference latitude, longitude, index and counts for that cell. The index is an offset into the data and time tag vectors so that the Level 2 data and corresponding time can be found for the Level 3 grid cell. The position of the latitudes and longitudes in the latitude/longitude vector is given by  $\text{index} \times 2$  and  $\text{index} \times 2 + 1$ . The value of count gives the number of data points that fall within that cell.

Each of the seven elements is given an identifier, which consists of a unique tag and reference number combination. These identifiers are then used to link the 7 elements into a group, which is referred to as a VGROUP. In situations where many different parameters are measured simultaneously at each location (such as the HIRS2/MSU soundings), the same time, lat/lon, and connectivity list entries may apply to many VGROUPs. The VDATAs for time, location, and connectivity list may be shared among multiple VGROUPs simply by linking with the identifiers of the common VDATA. This greatly reduces the file size—in some cases by as much as 75 percent.

Many atmospheric data fields can be represented as 3-D volumes. For example, with a global distribution of atmospheric temperature or humidity profiles on a lon/lat grid, the longitude and latitude positions are represented by x/y coordinates, whereas the levels of the profiles are represented with the z coordinate. A series of these volumes, possibly representing differing times, can be combined to make a fourth dimension. Cur-

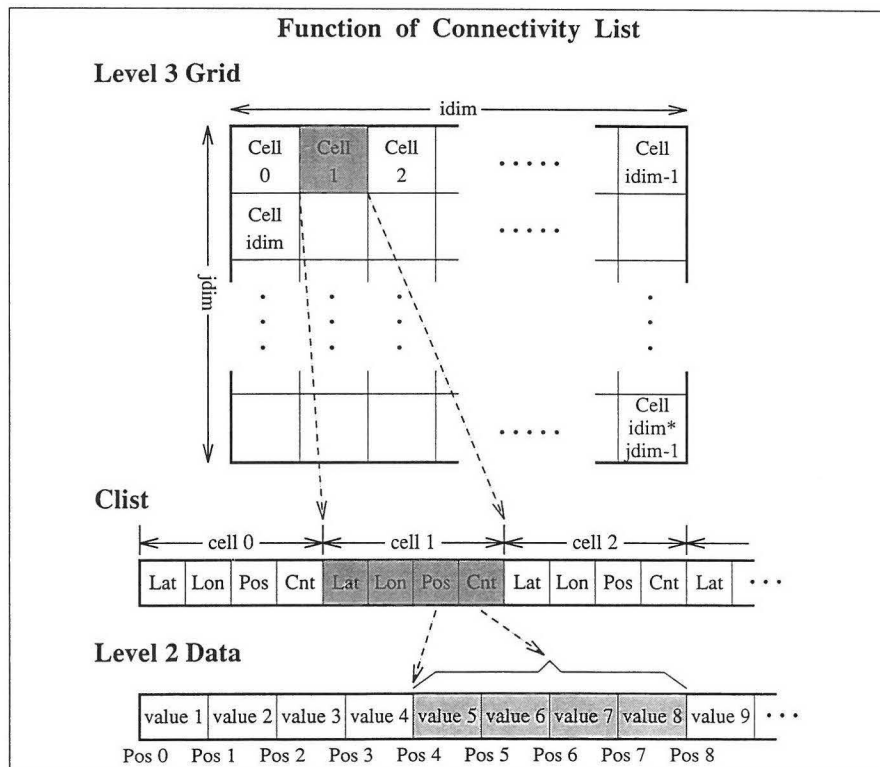

Figure 5. The Function of a Connectivity List in an Image/Vector File.

rently, Image/Vector files are designed for only 2-dimensional data sets. However, we are now designing the next generation of Image/Vector file so that they will be capable of storing 3-D (and possibly 4-D) data sets.

### Summary

With the help of new Interactive Data Language (IDL) programming capabilities and file structures made possible by Hierarchical Data Format (HDF), it is possible to obtain simultaneously the benefits of working with Level 3 (gridded) and the associated Level 2 (point) data, even for large, non-uniformly-sampled data sets. The Level 3 data provide an overview of the global characteristics of a measured parameter, whereas the Level 2 data contain

the precise values and sampling characteristics of the original observations. This information is needed for quantitative data analysis activities, such as validation. We are developing a way to realize the potential, through the WIGSS software and the underlying Image/Vector file structure.

We welcome further discussion of this material, and can be contacted via e-mail at [eda@cyclone.jpl.nasa.gov](mailto:eda@cyclone.jpl.nasa.gov).

### Acknowledgements

We thank our colleagues Jim Knighton, Sung-Yung Lee, Moustafa Chahine, and Richard Zurek of JPL, David Stern and Jong Yi of Research Systems, Inc., and Mike Folk, Jason Ng, and Shiming Xu of NCSA, for sharing

their insights with us on many aspects of this work. The Exploratory Data Analysis Team performed this work at the Jet Propulsion Laboratory, California Institute of Technology, under contract with the National Aeronautics and Space Administration. Primary support for the activities discussed here was provided by the Communications and Information Systems Division at NASA and the JPL Director's Discretionary Fund, with additional support from the Earth Science and Applications Division at NASA.

### References

Granger-Gallegos, R., A. Pursch, R. Kahn, and R.D. Haskins, Automatic Data Distribution for a Large Geophysical Data Set, *The Earth Observer*, July / August 1992.

Kahn, R.A., R.D. Haskins, J.E. Knighton, A. Pursch, and S. Granger-Gallegos, Validating a Large Geophysical Data Set: Experiences with Satellite-Derived Cloud Parameters, *Computing Science and Statistics*, Proceedings

of the 23rd Symposium on the Interface, 133-140, 1991.

Susskind, J., J. Rosenfield, and D. Reuter, An Accurate Radiative Transfer Model for Use in the Direct Physical Inversion of HIRS2 and MSU Temperature Sounding Data, *J. Geophys. Res.* **88**, 8550, 1983.

Susskind, J., Rosenfield, J., Reuter, D., Chahine, M.T., Remote Sensing of Weather and Climate Parameters from HIRS2/MSU on TIROS-N, *J. Geophys. Res.* **89**, 4677, 1984. □

## EOS Science Calendar

- January 6-9, 1993      HIRIS Team Meeting, Boulder, Colorado. Contact A. Goetz at (303) 492-5086
- February 1-5, 1993      Joint ASTER Science Meeting, Las Vegas, Nevada. Contact Dave Nichols at (818) 354-8912
- April 27-29, 1993      TES Team Meeting, Langley Research Center. Contact Reinhard Beer at (818)354-4748

## The Earth Observer

The Earth Observer is published by the EOS Project Science Office, Code 900, NASA /Goddard Space Flight Center, Greenbelt, Maryland 20771, telephone (301) 286-3411, FAX (301) 286-3884. Correspondence may be directed to Charlotte Griner at the above address. Articles, contributions to the meeting calendar, and suggestions are welcomed. Contributions to the meeting calendar should contain location, person to contact, and telephone number. To subscribe to The Earth Observer, or to change your mailing address, please call Hannelore Parrish at (301) 513-1613, or write to the address above.

**The Earth Observer Staff:**  
**Executive Editor:** Charlotte Griner  
**Technical Editor:** Renny Greenstone  
**Assistant Editor:** Mary Reed  
**Production:** Winnie Humberson  
**Distribution:** Hannelore Parrish

## Global Change Calendar

• 1992 •

- December 4-6 Computer Science for Environmental Protection, 6th Symposium, Munich, Germany, sponsored by German Computer Soc. Contact: Siemens Nixdorm Information System, phone: 49 89 636 48466.
- December 10-11 Surface Processes Airborne Research Management and Operations Working Group Meeting (SPARMOWG), Ames Research Center, Moffett Field, California. Contact: Ed Sheffner, phone: (415) 604-6565 or e-mail (ejsheffner@gaia.arc.nasa.gov).
- December 7-11 American Geophysical Union Fall Meeting, Civic Auditorium/Brooks Hall, San Francisco, California. Contact: Karol Snyder, phone: (202) 939-3205 or 1-800-966-2481; FAX: (202) 328-0566.
- December 8-12 Natural Hazards Induced by Environmental Changes Int'l Conference, (Zurich) Davos, Switzerland, Sponsored by European Foundation Commission of European Communities. Contact: Dr. Josip Hendekovic, European Science Foundation, 1 quai Lezay Mamesia, F-67000, Strasbourg, France.

• 1993 •

- February 8-11 Ninth Thematic Conference on Geologic Remote Sensing: *Exploration, Environment, and Engineering*, Pasadena, California. Contact: Robert Rogers, ERIM, Box 134001, Ann Arbor, MI 48113-4001 USA, phone (313) 994-1200, ext. 3234, FAX (313) 994-5123, telex: 4940991 ERIMARB.
- March 24-27 Sixth Annual Geographic Information Systems Conference (TSU/GIS '93). Contact: Dr. John M. Morgan, III, Department of Geography and Environmental Planning, Towson State University, Baltimore, Maryland 21204-7079, phone (410) 830-2964, FAX (410) 830-3482.
- April 4-8 25th International Symposium on Remote Sensing and Global Environmental Change, Graz, Austria. Sponsored by CIESIN (Consortium for International Earth Science Information Network), ERIM (Environmental Research Institute of Michigan), and Joanneum Research. Contact: Nancy Wallman, ERIM, P.O. Box 134001, Ann Arbor, MI 48113-4001, phone: (313) 994-1200, ext. 3234, FAX: (313) 994-5123.
- April 19-23 Call for Papers, First Thematic Conference, International Symposium "Operationalization of Remote Sensing". ITC, Enschede, The Netherlands. Contact: Prof. J.L. Van Genderen, ITC, P.O. Box 6, 7500 AA Enschede, The Netherlands, phone: 31-53-874-254, FAX: 31-53-874-436, telex: 44525 ITC NL.
- August 24-26 "Land Information From Space-Based Systems," Twelfth William T. Pecora Remote Sensing Symposium, Sioux Falls, South Dakota. Sponsored by the U.S. Geological Survey in cooperation with other Federal agencies. Contact: Dr. Robert Haas, Symposium Chairman, phone (605) 594-6007, or Dr. James W. Merchant, Program Chairman, (402) 472-7531, FAX: (402) 472-2410.

• 1994 •

- Jan. 31-Feb. 2 Second Thematic Conference on Remote Sensing for Marine and Coastal Environments, New Orleans, Louisiana. Contact: Robert Rogers, ERIM, Box 134001, Ann Arbor, MI 48113-4001, phone (313) 994-1200, ext. 3234; Fax (313) 994-5123.

---

Code 900  
National Aeronautics and  
Space Administration

**Goddard Space Flight Center**  
Greenbelt, Maryland 20771

Official Business  
Penalty for Private Use, \$300

Postage and Fees Paid  
National Aeronautics and  
Space Administration  
NASA-451

