



The Earth Observer

An EOS Periodical of Timely News and Events

Vol. 4, No. 2

March/April 1992

Inside

Change in Management	2
News From The EOS Science Executive Committee	3
Science Team Meeting	
MISR Science Team Meeting	4
Articles	
Acquisition, Processing and Distribution of Data Products for The EOS AM-1 Instruments	7
Ocean Climate Data Workshop Looks Toward the Future and Into the Past	10
Calendar of Meetings	
EOS Science Meetings	13
Global Change Meetings	14
Subscription/Information	15

EDITOR'S CORNER

NRC'S INTERIM REPORT ON EOSDIS

The National Research Council released on April 17 a 30-page Interim Report of its Panel to Review EOSDIS Plans. Its recommendations about the importance, scope, and objectives of EOSDIS are consistent with those made by the Earth science community over the past four years.

The Panel finds that the recent restructuring of the EOS mission, from two large satellites with a total of 30 instruments to a series of six smaller spacecraft with a total of 20 instruments, results in only a 15% reduction in data rates (to 1.1 terabytes/day). Hence the restructuring of EOS has had little effect on the requirements for EOSDIS.

The Panel's recommendations are cast in terms of the following objectives it believes essential to the success of EOSDIS, which must:

- facilitate integration of data related to the U.S. Global Change Research Program;
- serve a large, broad set of users, by providing information simply, transparently, and

inexpensively, assuring availability of its data to the science community;

- ensure that service to current users is not interrupted as the system develops;
- maintain the flexibility, as it evolves, to build rapidly on advances in computer science and technology;
- incorporate substantive user participation in design and development of the system.

The Panel believes that NASA can proceed with the EOSDIS procurement, provided that the agency builds in the flexibility to adjust as necessary to ensure success, incorporating flexibility into work

plans during the contract negotiations that will take place beginning in mid-summer. The Panel states that this flexibility could be accommodated within the scope of the current EOSDIS procurement, as long as it is planned ahead of final contract negotiations and as long as contract terms are compatible with this approach. The Panel believes that its recommendations should not affect the schedule of EOSDIS, and recognizes the importance to the user community of implementing EOSDIS as soon as possible.

Copies of the Interim Report are available from the National Research Council, Space Studies Board, 2101 Constitution Ave., N.W., Washington, D.C. 20418. □

CHANGE IN MANAGEMENT

John Dalton, Chief of the Data System Technology Division at the Goddard Space Flight Center, has been selected as the new Project Manager of the EOS Ground System and Operations Project, with responsibilities for the EOS Data and Information System (EOSDIS, replacing Tom Taylor who recently retired).

Dalton has over 21 years of experience in the development and application of information systems technology to the acquisition, management, display, and analysis of data from NASA missions. In 1983 he managed the formation of the Data Systems Technology Division at the Goddard Space Flight Center, and has directed the Division's applied R&D projects in high-performance Very Large Scale Integration (VLSI)-based systems, data management, software engineering, human factors, distributed systems, and expert systems. Products of the Division include the Transportable Applications Environment (TAE) Plus, a workbench for the development and generation of graphic user interfaces that is now in use at over 600 sites worldwide; and a modular telemetry system architecture based on high-performance VLSI and commercial components that is in use at Wallops and Deep Space Network tracking stations and for Space Station Freedom, TOPEX, and Small Explorer missions.

Prior to 1983, Dalton served for 6 years in Branch Head and Section Head positions in the Information Extraction Division of the Applications Directorate, where he managed the development of image processing systems for display and analysis of remote sensing satellite data for meteorological and Earth resources applications, and developed analysis algorithms, systems software, and computer system configurations for high-performance interactive manipulation of image data. During this time, he also led software development for a White House-initiated decision support system project to interactively integrate and display geographic statistics from 20 Federal agencies.

Prior experience includes the development of software systems for data processing, information management, display, and scientific analysis for cosmic ray experiments on IMP's 6, 7, 8, and Pioneer 10.

Dalton holds a Master of Engineering Administration from George Washington University, a Master of Science in Computer Science, and a Bachelor of Science in Physics from the University of Maryland.

Jerry Madden
Associate Director of Flight
Projects for EOS

News From The EOS Science Executive Committee

Renny Greenstone,
EOS Project Science Support Office, Hughes STX

T

he Science Executive Committee (SEC) of the EOS Investigators Working Group (IWG) met in Washington, DC on March 5 and 6, 1992. This was the first formal appearance of Ghassem Asrar in his new role of EOS Program Scientist and, therefore, co-chair with Jeff Dozier of the SEC.

Among the significant outcomes of the meeting were these: the next IWG meeting is to be held in Keystone, Colorado on July 20-22; an electronic bulletin board is to be set up for EOS (see Editor's note on page 13); the SEC has prepared and sent to the Congress a letter giving affirmation of the Payload Panel's recommendations for the restructured EOS observation program and the manner in which NASA proposes to respond to those recommendations. In regard to this last point, Shelby Tilford urged that the restructured EOS program receive strong support from the Earth science community.

Dixon Butler advised the Committee members that he now has the added duty of serving as

NASA's Mission Operations and Data Analysis Manager for Landsat. Landsat-7 is to be launched in mid-1997, with launch vehicle and spacecraft being supplied by the Department of Defense, and Mission Operations and Data Analysis plus Tracking and Data Relay System (TDRSS) communications being supplied by NASA.

A great deal of the concern of this SEC meeting was with the need to establish better communication ties with both the EOS community and the larger Earth Science community. In recognition of this problem it was agreed to set up the EOS electronic bulletin board (mentioned earlier) and to provide more information about EOS to publications such as *Eos Transactions of the AGU*, the National Academy of Sciences publication, *Issues in Science and Technology*, and the *Journal of Geophysical Research*. Another suggestion was to have specific EOS-related interdisciplinary sessions of organizations such as the American Geophysical Union and the American Meteorological Society.

Special workshops on specific areas of EOS science would be a way to reach more of the Earth science community. Videos of such workshops could be distributed widely.

The EOS Reference Handbook has proven to be a very handy way of letting the community know about EOS plans and activities. The 1992 revision of the Handbook is now being prepared with improved scientific instrument descriptions and more information on the scientific knowledge to be provided by the instruments. More space may be added to describe the activities of the interdisciplinary science investigators.

A recent significant accomplishment for EOSDIS was the linking of four EOS Distributed Active Archive Centers (DAACs), permitting a live, user-transparent data search, with the returns from all four DAACs merged and processed.

The next meeting of the SEC is scheduled for May 15 in Chicago, timed to follow the AGU meeting in Montreal. □

MISR Science Team Meeting

*David J. Diner, MISR Principal Investigator
Jet Propulsion Laboratory
(Assisted by Daniel Wenkert, NASA HQ)*

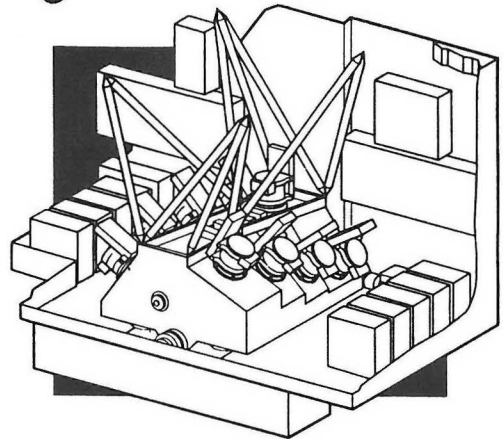

On February 27-28, 1992, a meeting of the Multi-Angle Imaging SpectroRadiometer (MISR) Science Team was held at the Jet Propulsion Laboratory in Pasadena, CA. Eight of the nine MISR Science Team members attended or sent a representative. Other participants included members and affiliates of the MODIS Land Group, GSFC scientists, members of the JPL MISR Project management, instrument engineering, science, and data processing staff, and representatives from the GSFC EOS-AM Project Office and NASA HQ.

Bruce Guenther, the EOS-AM Observatory Project Scientist, began the first day's meeting by describing the restructured EOS Project structure at GSFC and giving an overview of EOS programmatic. He and Tom Ackerman, MISR Science Team member from Pennsylvania State University, gave their impressions of the recent CEES Small Satellite Workshop, at which several proposals for the Climsat mission were presented.

Dave Diner, MISR Principal Investigator from JPL, announced the recent receipt of the MISR reconfirmation letter for the EOS-AM mission from Len Fisk and the formation of a MISR Project Office at JPL. He gave an update and status report on the MISR instrument design and development. He also described the engineering team's activities regarding the manufacture of a brass-board nadir camera.

A detailed discussion of MISR operating modes was held. MISR's capability in providing global 1.92 km resolution data, global high resolution (240 m) stereoscopic data, and targeted observations at high resolution results in a discrete number of operating modes with different data rates. The EOS Project Office, in an effort to reduce the number of platform tape recorder speed changes, has asked the MISR team to review the instrument operation to determine if the number of data modes could be reduced. In addition, since the MISR instrument is capable of providing data at 960 m resolution, the representatives of the MODIS team expressed a desire for such data over land, a modification to the current MISR mission plan. Consensus on a number of operating scenarios that met the objectives of both the MISR and MODIS scientists was achieved; however, reduction in the number of discrete instrument data rates carries the penalty of an increase in the average instrument data rate. Bob Rice of JPL presented a tutorial on data compression. The JPL MISR Project, the GSFC EOS Project, and GE will work together to reach an accommodation of scientific, instrument, and platform interests regarding data rates.

Roger Davies, Science Team member from McGill University, described his cloud studies activities. He and his students are examining the use of spectral angular signature as a means of discriminating homogeneous

clear sky, fog, and cirrus. Additional efforts are concentrating on the development of broken cloud models in order to predict the radiation field at azimuthal angles not observed by the MISR instrument.

Science Team member, Peter Muller of University College, London, described his activities regarding the development of image-matching techniques for digital topography and cloud elevation retrieval using MISR stereo data. Ken Jones of JPL followed with a discussion of requirements and challenges involved in processing of MISR Level I data. He and Peter Muller agreed that establishment of pre-mission reference images (e.g., from Thematic Mapper) will be necessary to ensure properly geolocated data sets from MISR. Various members of the MISR team were charged with the responsibility to evaluate cloud identification algorithms. The team expressed interest in convening a cloud-masking workshop to report on progress in about six months, with participation from representatives of other EOS-AM instruments to be encouraged.

Graham Bothwell of JPL described the MISR data processing hierarchy, and discussed the practical differences between standardized, specialized, and prototype data products. Assignments of responsibilities of team members with respect to Level I and Level II algorithm development were reviewed. CoI's will be responsible for providing algorithm theoretical descriptions, prototype code (in some instances), and test data. The timeline for development of processing software was shown. Guidelines on software engineering and standardization were also discussed.

Chris Borel of Los Alamos National Lab, representing Science Team member Sig Gerstl, described various mathematical methodologies for representing bi-directional reflectance distribution functions (BRDF's). Inversions of a physical BRDF model, assuming observations at the MISR view angles, indicate the potential for retrieval of canopy structural parameters.

Alan Strahler of Boston University, member of the MODIS team, presented ideas for establishment of a Joint MODIS-MISR Working Group. It was agreed that many items of mutual concern to both teams will benefit from continued informal interactions, attendance at each other's team meetings, and

occasional meetings of designated representatives of each team to achieve closure on issues such as cross-calibration, image registration, and map projections.

John Martonchik, MISR Algorithm/Data Scientist from JPL, presented the results of his research into development of aerosol and surface reflectance retrieval algorithms over land. The aerosol retrieval technique presented uses a spatial Fourier transform of the multi-angle images to constrain aerosol opacity, single scattering albedo, and phase function asymmetry parameters. The surface reflectance retrieval is accomplished by an iterative inversion of the top-of-atmosphere radiance field. Integration over angle is then used to obtain hemispheric albedo.

Tom Ackerman presented some of the recent thinking on the importance of anthropogenic aerosols to the climate system. For retrieval of tropospheric aerosol properties using MISR, he pointed out that a better understanding of the effects of humidity on aerosol optical properties is needed, and he is proposing to undertake an experimental study at Penn State. The importance of SAGE data in the same time frame that MISR is flying was emphasized. A letter from the MISR team to NASA HQ stressing this point was drafted and sent. Finally, the need for better models of the phase functions of non-spherical particles, such as smoke and dust, was discussed. Bob West of JPL made a presentation on plans to address this issue by obtaining laboratory measurements in conjunction with theoretical studies using non-spherical particle scattering codes.

Howard Gordon, Science Team member from the University of Miami, presented recent theoretical results on aerosol retrievals over oceans. His approach is a multi-angle extension of CZCS, SeaWiFS, and MODIS techniques, and relates the top-of-atmosphere radiation field to the aerosol single scattering phase function. Initial results are very encouraging and emphasized the need for better aerosol models.

Jim Irons of GSFC discussed the status of the Advanced Solid-State Array Spectroradiometer (ASAS), a multi-angle aircraft imager. ASAS data are of particular interest to aid in the development of MISR algorithms, and GSFC has recently installed a new mount to enable acquisition over a

wider range of view angles than previously possible. Earl Hansen of JPL and Peter Muller reported upon efforts to develop techniques for geometrically registering the ASAS multi-angle images.

Members of the MISR engineering staff, Virginia Ford, Mary White, Larry Hovland, Enrique Villegas, and David Osborn, gave a "show and tell" presentation on the brass-board camera mechanical hardware, optics, focal plane, signal chain electronics, and ground support equipment. The camera is expected to be ready for testing this summer.

Following the hardware viewing, MISR Calibration/Validation Scientist Carol Bruegge of JPL led a discussion on various field programs of interest to MISR. Tom Ackerman gave a status report on the DOE ARM program and Eric Vermote of GSFC discussed a smoke and cloud radiative transfer experiment being planned for Brazil with MODIS

support. Ideas for participation in BOREAS were also discussed.

Carol Bruegge then gave a presentation on MISR calibration activities. The MISR team has been aggressively investigating candidate materials to serve as diffusing targets for in-flight calibration. Spectralon is presently favored because of its lambertian nature and high reflectivity, but an electrostatic charge build-up problem will require solution before the material can be space qualified. A number of solutions are being investigated. The use of detection-based calibration techniques, both pre-flight and in-flight, and formal statistical methods for verifying and reporting instrument calibration and radiometric performance, were also discussed.

Dave Diner concluded the meeting with a review of decisions and task assignments. The next full team meeting is planned for next winter or spring. □

EOS AM On-Orbit Configuration

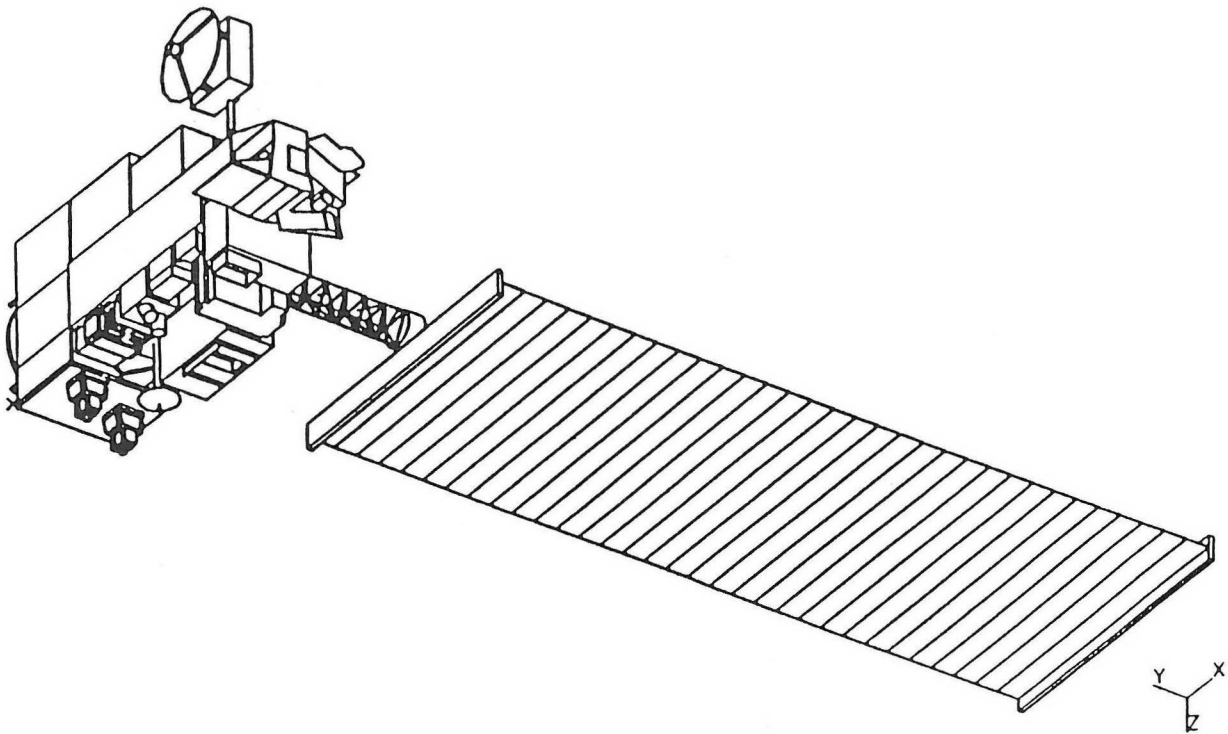

Acquisition, Processing and Distribution of Data Products for The EOS AM-1 Instruments

E. Chang, EOS AM Project Operations Manager
 B. Guenther, EOS AM Project Scientist

INTRODUCTION

This summary emphasizes how the AM Spacecraft instruments will be used to acquire the scientific data sets from which the EOS science will be developed. The AM-1 Spacecraft houses the five science instruments: ASTER, CERES, MISR, MODIS-N and MOPITT. This article also identifies techniques for near-real-time data collection by investigators during field campaigns, where normal access through the ground data system is not adequate.

The article is designed to encourage and generate an exchange of information between the science users and EOS Project personnel. All data will be archived within the Earth Observing System Data and Information System (EOSDIS), and access to the EOSDIS will be through the Distributed Active Archive Centers (DAACs) primarily .

END-TO-END DATA FLOW

Spacecraft Operations

Normally, EOS AM spacecraft operations will be pre-planned. Instrument activities will be initiated from time-tagged stored commands. Data is routed on-board from an instrument to the tape recorder in a CCSDS format. Under normal

circumstances all science data will be recorded onboard the spacecraft. The data will be downlinked during one or two Tracking and Data Relay Satellite System (TDRSS) Ku-band Single Access (KSA) contacts per orbit. The High Rate Tape Recorders (HRTRs) will store all data produced by the EOS AM spacecraft, and replay them during scheduled contacts. Assuming nominal instrument operating scenarios, each recorder will have the capacity for storage of more than one orbit of data. Playback rate of the HRTRs will normally be 150 Mbps. Command operations will occur during science data downlinks. Additional services in science data communications include direct broadcast, direct downlink and direct playback.

Return Link Service	EOS Antenna	Max Data Rate		Usage
		I	Q	
TDRSS Link	HGA* (Ku-band)	75 Mbps	75 Mbps	Primary mode of data transmission to ground, also capable of real-time transmission.
DB (Direct Broadcast)	DAS* (X-band)	15 Mbps	15 Mbps	Real-time, continuous direct broadcast of MODIS-N and ancillary data.
DDL (Direct Downlink)	DAS* (X-band)	15 Mbps	105 Mbps	Real-time direct downlink of ASTER and ancillary data on Q channel and MODIS-N data on I channel, on a scheduled basis.

(Note: Not simultaneous with DP)

* See Glossary at end of this article

Spacecraft Telemetry

S-band telemetry

Spacecraft and instrument housekeeping data will be transmitted to the ground via the S-band telemetry stream. Up to 16 Kbps are available for real-time transmission of these data during scheduled TDRSS contacts.

Ku-band telemetry

EOS Ku-band telemetry will consist of the following:

- a) science data from each of the instruments,
- b) spacecraft-provided engineering data from the spacecraft and instruments, and
- c) additional spacecraft data.

Science and engineering telemetry will be transmitted via the high gain antenna to TDRSS on a Ku-band frequency. The spacecraft provides the capability to continuously record all science data from all instruments.

Direct Broadcast, Direct Downlink, Direct Playback

Three X-band services are offered by the spacecraft: Direct Broadcast (DB), Direct Downlink (DDL), and Direct Playback (DP). Each of these services is described in the following paragraphs. In any case, DB, DDL, or DP, the same science data interfaces between the instruments and the spacecraft will be used as for the TDRSS Ku-band transmission. The spacecraft will forward the instrument data to the X-band modulators as required.

Direct Broadcast will provide users with direct access to data via a user-provided ground station. Direct Broadcast data will be from MODIS-N and ancillary data that will be transmitted by the spacecraft in near real-time. Direct Broadcast transmission will be continuous and generally will not be schedule-driven or dependent upon any specific ground station. DB data is intended to be broadcast to a general community of users who can receive the data with their user-provided ground stations. Direct Broadcast data will be transmitted at 15 Mbps, is designed to operate with a 10 Watt (TBD) transmitter, and will require at least a 3 m ground antenna to receive the data.

ASTER is the only instrument identified as requiring direct downlink transmissions. Direct Downlink data will be scheduled and transmitted only during short contact periods when the spacecraft is within the view of a selected user ground station and ASTER is gathering science data. Direct Downlink data will be transmitted at 105 Mbps.

Ground System Operations

Level 0 Processing

All EOS science and engineering data for the instruments and spacecraft will be processed by EDOS through Level 0 Processing (LZP), which will result in LZP files. All LZP files will be transmitted automatically to the appropriate DAAC(s) (or to the corresponding Japanese facility in the case of ASTER data) as soon as possible after the LZP file has been constructed. The delay for the construction of the LZP file is proportional to the amount of data to be processed. LZP data products are available within 21 hours of receipt of the complete input data sets for those products. The data are transmitted via the EOS Communications (ECOM) system.

Quick Look Processing

EDOS will provide the capability to generate quick look files to support the need for science data with lower time delays than those associated with LZP files. The quick look file is normally available for delivery within 1 hour of completion of the TDRSS service session. The data used for quick look file generation also may be used for the generation of routine LZP files with the same Application Process Identifier (APID). The amount of data that may be quick look processed per day is limited to 10 (TBD)% of the total daily instrument data volume.

Return Link Real-Time Processing

EDOS will provide the capability to receive, process and deliver selected packet data in real-time. This capability is intended in particular for the handling of the spacecraft engineering data that are transmitted through the TDRSS SSA service.

The spacecraft has the capability to transmit instrument science data in real-time through the TDRSS KSA service. Routing on the ground to the users is being studied.

The DAACs will receive Level 0 processed data from EDOS. Level 0 data is defined as raw instrument data at original resolution, time ordered, with duplicates removed. The DAACs will process data to various levels including the following:

- Level 1A Level 0 data, which may have been reformatted or transformed reversibly, with spacecraft ephemeris and attitude data appended, and packaged with needed engineering data.
- Level 1B Irreversibly transformed values of the instrument measurements (e.g., measurement counts irreversibly transformed to radiances).
- Level 2 Geophysical parameters, located in space and time, generally commensurate with observations.
- Level 3 Geophysical parameters resampled onto space-time grids.
- Level >3 Higher levels are defined differently in various contexts.

The DAACs will generate Level 1 Standard Products within 24 hours after the availability of all necessary input data sets. The DAACs will generate Level 2 Standard Products within 24 hours after the availability of all necessary Level 1 and other input data sets. The DAACs will generate Level 3 Standard Products within 24 hours after the availability of all necessary Level 2 and other input data sets. The DAACs will generate Level 4 Standard Products within 72 hours after the availability of all necessary Level 3 and other input data sets. The DAACs will generate quick-look products as soon as possible after the receipt of the necessary input data for a maximum of 10(TBD)% of the EOS instrument data.

CLOSING REMARKS

This summary of the EOS AM-1 Spacecraft DB/DDL data services is intended to assist the science community in long-term planning for field campaigns and ground truth investigations. Comments on the approaches described here are welcomed by Ed Chang, Code 421, or Bruce Guenther, Code 925, Goddard Space Flight Center. □

GLOSSARY

APID	Application Process Identifier
ASTER	Advanced Spaceborne Thermal Emission and Reflection Radiometer
CERES	Clouds and the Earth's Radiant Energy System
CCSDS	Consultative Committee for Space Data Systems
DAAC	Distributed Active Archive Center
DAS	Direct Access System
DB	Direct Broadcast
DDL	Direct Downlink
DP	Direct Playback
ECOM	EOS Communications System
EDOS	EOS Data Operations System
EOS AM	Earth Observing System - 10:30 a.m. descending node orbit
EOSDIS	EOS Data and Information System
GSFC	Goddard Space Flight Center
HGA	High Gain Antenna
HRTR	High Rate Tape Recorder
I	In-Phase (one channel of QPSK transmission)
Kbps	Kilobits per Second
KSA	Ku-Band Single Access
LZP	Level Zero Processed
Mbps	Megabits per Second
MISR	Multi-Angle Imaging Spectro-Radiometer
MODIS-N	Moderate Resolution Imaging Spectro-Radiometer-Nadir
MOPITT	Measurements Of Pollution in the Troposphere
Q	Quadrature Phase QPSK
SSA	S-Band Single Access
TBD	To Be Determined
TDRSS	Tracking and Data Relay Satellite System

Ocean Climate Data Workshop Looks Toward the Future and Into the Past

Jim Acker, EOS Oceans Liaison, Hughes STX

Data management needs of the oceanographic future and the historical data record from nearly a century of research were the main considerations of an "Ocean Climate Data Workshop," hosted by NASA and the National Oceanic and Atmospheric Administration (NOAA) at Goddard Space Flight Center on February 18-21, 1992. The meeting's main purpose was to improve communications between data managers and scientists in the 1990s, as oceanography contends with increasing volumes of data relevant to climate change research.

During the first day's "Introduction to the Workshop," the attendees heard NOAA director John A. Knauss discuss how the traditional concept of a constant, invariant ocean has shifted to a new awareness of the ocean's variable dynamics. Stan Wilson, former EOS Program Scientist, spoke on the role of the Earth Observing System in ocean climate studies. Wilson noted that a "remarkable" capability is currently being developed to observe global ocean processes, and he stressed the importance of combining this capability with at-sea research. Participants also heard Rear Admiral G.L. Chesbrough,

Oceanographer of the Navy, discuss the Navy's use of climate data to prepare nowcasts and forecasts in support of fleet operations. The Navy's operational ocean models use ocean climate data to fill spatial and temporal gaps in ship report coverage and to improve the quantification of oceanic variability. Ferris Webster of the University of Delaware discussed the role of World Data Centers in the acquisition and distribution of ocean climatological data.

The workshop's second session allowed scientists to interact with computer systems in a hands-on session organized by the staff of NASA's Climate Data System (NCDS). Prior to the interactive session, convener Lola Olsen of NCDS, discussed the development of the Goddard DAAC. Chuck McClain of NASA's Laboratory for Hydrospheric Processes described SEAPAK, a PC-environment oceanographic analysis software package. Tony Busalacchi, Chief of the Laboratory for Hydrospheric Processes, introduced the attendees to oceanographic data analysis methods used at Goddard. Peter Topoly described the POSEIDON relational database being developed by the National Ocean Data Center

(NODC), and Elizabeth Smith of JPL focused on ATlast and Ocean Atlas software. Jim Kinter (U. Maryland) introduced GRADS (Grid Analysis and Display System), a tool for Earth sciences visualization. During the interactive session, attendees saw demonstrations of POSEIDON, GRADS, SEAPAK, Ocean PC from the Intergovernmental Oceanographic Commission (IOC), ATlast, and oceanographic visualization software developed by NASA and Florida State University to analyze ocean model data.

The third session was devoted to the topic of monitoring changes in the ocean and atmosphere. Individual subjects focused on the design and goals of the World Ocean Circulation Experiment (WOCE), the Global Temperature-Salinity Pilot Project (GTSP), physical oceanographic analyses of the Indian Ocean using expendable bathythermographs (XBTs) deployed from ships of opportunity, global ocean surface variations, and the coupling of remotely-sensed data with fisheries oceanography.

The most challenging topic discussed in this session was the design of the Global Ocean Observing Session (GOOS), pre-

sented by Dana Kester of NOAA. GOOS intends to measure wind speeds over the ocean, sea surface temperatures, depth profiles of temperature and salinity, sea level, sea ice extent, and the carbon dioxide and chlorophyll content of surface waters. GOOS is envisioned as having four divisions: satellite observations, *in situ* observations, numerical modeling of ocean processes, and data exchange/management. Kester stated that GOOS is needed to augment the oceanographic data requirements inherent in analyses of the ocean's role in global change issues. GOOS will aid the development of "operational" El Niño-Southern Oscillation forecasting, and provide more complete data for ocean circulation models. Another rationale for GOOS is "to extract the greatest value" from the substantial investment of world space agencies in remote ocean sensing in this decade. Kester noted that thorny issues of data consistency and quality will require close coupling of science and data management.

The fourth session, "Data Archaeology," dealt with the historical aspects of ocean climate data. Historical data can be very useful to climate change studies, as it provides a long-term database. However, much of this data is unavailable due to inaccessible formats (including paper!), variability of data types, and the problem of "metadata" (data associated with the raw numbers, such as the method of analysis, and spatial and temporal location). Syd Levitus, head of NOAA's data archaeology program, began the session with a discussion of "Ocean Climate Diagnostic Stud-

ies." Other speakers discussed satellite altimetry, global circulation modeling, the data archaeology program in the Commonwealth of Independent States, and the difficulties experienced by developing countries in West and Central Africa in obtaining data for use in ocean climate and coupled land-ocean climate research.

In the following session, "Effect of Change in the Ocean and on the Life Cycle," Hugh Ducklow of the University of Maryland discussed the goals of the Joint Global Ocean Flux Study (JGOFS), and the first JGOFS process study, the North Atlantic Bloom Experiment (NABE). JGOFS presents a data management challenge because it is analyzing a larger number of variables than previous studies and because it also determines 12 different rates (such as primary productivity), requiring larger amounts of metadata. Ducklow presented some of the current results of NABE. He also stated that the long-term goal of JGOFS is to obtain global, seasonal distributions of biogeochemical parameters. SeaWiFS will be important to multi-year integration of the results from one-year ocean basin process studies.

Glenn Flierl of the Woods Hole Oceanographic Institute discussed the design of the data management system for JGOFS, following an object-oriented programming design. Roy Lowry of the British Oceanographic Data Centre described the successful methods the British Ocean Flux Study (BOFS) had used to make data management tractable. BOFS made data managers part

of the science team, and the quality-control process for the data was interactive between the Data Centre and individual scientists.

Satellite data assimilation and management in JGOFS, including NOAA AVHRR sea-surface temperature and SeaWiFS ocean color, was discussed by Robert Evans (University of Miami). SeaWiFS data products are planned to range from "quick-look" products, available 2-10 days after data acquisition, to "validated" products, which will be available approximately 6 months after data acquisition. The acquisition of validated ancillary and *in situ* data is the main factor determining the waiting period for high-quality, validated data fields developed from satellite observations.

At nearly the opposite end of the spectrum from SeaWiFS technology is the continuous plankton recorder (CPR), heart of an oceanic survey begun in the 1920s. John Gamble described the system, which deploys the CPR from commercial ships in the North Atlantic. Gamble noted that this long-term record of plankton populations, classified by 400 different types, could be integrated with other research programs. The entire database is now being transferred to a single personal computer.

Anthony Michaels of the Bermuda Biological Station discussed the data management techniques used by the Bermuda Atlantic Time-Series (BATS). BATS, a component of JGOFS, performs monthly sampling at a station

near Bermuda. Tommy Dickey of the University of Southern California spoke on automated observing technology for upper-ocean oceanography. Dickey stressed that the data densities (temporal and spatial) inherent in this new technology will rapidly increase the volume of *in situ* oceanographic data, a point also noted by Michaels.

The final day of the meeting consisted of a wrap-up panel discussion chaired by Geoffrey Holland. The panel formulated recommendations for national and international oceanographic organiza-

tions. The discussion highlighted several important areas, including the necessity of data preservation from historical data sets, the importance of improved quality control methods, and the problems presented by the large volume and intensive assimilation protocols unique to satellite data. Other topics concerned addressing the evolution of all types of ocean climate data sets, primarily their increasing size and complexity; improved means for allowing access to data for researchers in developing countries; recommendations for the structure of GOOS; and funding

issues, principally the shift from research funding to operational funding of GOOS.

Attendees at the Ocean Climate Data Workshop received a new visualization of the "two-faced genie" in the data bottle: the useful aspect of increasing spatial and temporal sampling density, which will aid progress in climate and global change studies; and the dangerous aspect of massive volume and complexity, which threatens to overwhelm the capacities of obsolete archival and retrieval systems. □

NSI-NIC Network

Ever had a networking question and you couldn't find anyone to answer your question? The NASA Science Internet (NSI) is an international dual-protocol (TCP/IP and DECnet) network whose function is to support and facilitate research among NASA's scientists and engineers. Two previous networks, Space Physics Analysis Network (SPAN) which contained the DECnet component and the NASA Science Network (NSN) which contained the TCP/IP component, no longer exist as separate networks but have been incorporated into the NSI since 1990. NSI has a Network Information Center (NIC), complete with its own Help Desk, staffed with networking experts to answer user questions, solve problems, and refer users to various other sources. They can be contacted by electronic mail or by telephone. The NSI NIC also offers other services such as an anonymous FTP site with numerous useful sets of network information and software utilities in the data archives (the NSI File Cabinet), an on-line networking help utility (NONA), and the capability for custom network user services, both information requests and networking application services requests.

The NSI NIC Help Desk can be contacted by E-mail:

(for NSI-TCP/IP): help@nic.nsi.nasa.gov

(for NSI-DECnet): `nsinic:help`

or by phone:

301-286-7251, FAX: 301-286-5152

The anonymous FTP site, the NSI File Cabinet, can be accessed by E-mail:

(for NSI-TCP/IP) : [ftp nic.nsi.nasa.gov](ftp:nic.nsi.nasa.gov)

(for NSI-DECnet): `set default`

`nsinic:nic_files:[000000]`

Use the DECnet COPY to copy files

The NSI Online Network Aide, NONA, can be accessed by E-mail:

(for NSI-TCP/IP): [telnet nic.nsi.nasa.gov](telnet:nic.nsi.nasa.gov)

username `nsinic`

(for NSI-DECnet): `set host nsinic username`

`nsinic`

*Yonsook Enloe, NSI-NIC Staff
Goddard Space Flight Center*

FLASH.....

EOS Bulletin Boards are now operational on OMNET and GSFCMail. To read the latest news, access EOS.NEWS on both GSFCMail and OMNET. Only the Project and Program Offices at NASA Headquarters and Goddard Space Flight Center can post messages to these bulletin boards. Readers who have contributions should submit them to J. DOZIER or G. ASRAR on OMNET.

— Editor



Renny Greenstone (L), Hughes STX, and Phil Ardanuy (R), RDC, manned an EOS booth at the International Space Year Conference held in Munich, Germany, March 30-April 6.

EOS Science Calendar

- | | |
|-----------------|---|
| June 5-6 | HIRIS Team Meeting, JPL, CA. Contact A. Geotz at (303) 492-5086. |
| June 9-10 | Graduate Student Fellowships in Global Change Research Panel Meeting, Washington, DC. Contact G. Asrar at (202) 453-1759. |
| June 15-16 | SAGE III Science Team Meeting, Newport News, VA. Contact Patrick McCormick at (804) 864-2669. |
| Week of June 22 | ASTER Team Meeting, Japan. Contact A. Kahle at (818) 354-7265. |
| June 23-26 | Land Science Meeting, Columbia, MD. Contact P. Sellers at (301) 286-3720. |
| July 20-22 | EOS Investigators Working Group Meeting, Keystone, CO. Contact J. Dozier at (301) 286-8228 or G. Asrar at (202) 453-1759. |
| July 28-30 | LAWS Science Team Meeting, Cape Cod, MA. Contact W. Baker at (301) 763-8005. |
| August 17 | MISR Cloud Masking Workshop, Montreal. Contact R. Davies at (514) 398-3663. |
| September 14-18 | EOS Calibration Panel Meeting, Logan, Utah. Contact Bruce Guenther at (301) 286-5205. |
| October 13-15 | TES Meeting, Atmospheric & Environmental Research, Boston. Contact Reinhard Beer at (818) 354-4748. |
| October 27-29 | MODIS Team Meeting, University of CA, Santa Barbara. Contact Steve McLaughlin at (301) 286-9515. |

Global Change Meetings

• 1992 •

- June 8-9 Space Science and Advanced Technologies Conference, Washington, DC. Ramada Renaissance Hotel. Phone: (301) 534-3922; FAX: (301) 534-0743.
- June 14-17 ECO World 92' Conference, Washington, D.C. Contact: ASME 345 East 47th Street, New York, N.Y. 10017. Phone: (212) 705-7148; FAX: (212) 705-7143.
- June 15-17 The First Thematic Conference on Remote Sensing for Marine and Coastal Environments: *Needs and Solutions for Pollution Monitoring, Control, and Abatement*, New Orleans, Louisiana. Contact Nancy Wallman, ERIM, Box 134001, Ann Arbor, MI 48113-4001. Phone: (313) 994-1200, ext. 3234; FAX: (313) 994-5123; Telex: 4940991 ERIMARB.
- June 22-26 International Symposium on Environmental Sensing, Berlin Gemany, sponsored by SPIE/EOS. Contact SPIE, P.O. Box 10, Bellingham, WA, 98227. Phone: (206) 676-3290; FAX: (206) 647-1445.
- July 19-Aug. 8 A NATO Advanced Study Institute, *Remote Sensing and Global Climate Change*, 7th Dundee Summer School in Remote Sensing, University of Dundee, Scotland, U.K. Contact Robin Vaughan. Phone: (0382) 23181, ext. 4557/4912; FAX: (0382) 202830; Telex: 9312110826 DUG.
- July 20-24 Synthetic Aperture Radar Technology and Applications, a five-day short course, offered through Engineering Conferences at the University of Michigan. Contact Dr. Robert Shuchman. Phone: (313) 994-1200, ext. 2590.
- August 2-14 XVII Congress of the International Society for Photogrammetry and Remote Sensing (ISPRS), Washington, D.C. Concurrent to the ISPRS Congress, two other meetings will be held nearby: the ASPRS and the American Congress on Surveying and Mapping (ACSM) will conduct a conference on Global Change; the International Geographical Union will convene its 27th International Geographical Congress (IGC) during the second week. For more information contact XVII ISPRS Congress Secretariat, P. O. Box 7147, Reston, Virginia 22091.
- August 17-20 Satellite Remote Sensing for Resource Management, Environmental Assessment, and Global Change Studies: *Needs and Applications of Developing Countries*, Boulder, Colorado. Contact Theresa Schwerin, Reference: UN/ISY Conference WT Chen & Company, Inc., 1745 Jefferson Davis Highway, Suite 500, Arlington, Virginia 22202. Phone: (703) 769-1800; FAX: (703) 769-1803.
- August 24-28 The 1992 STEP Symposium-COSPAR Colloquium No. 5, Johns Hopkins University. Contact Dr. Michael Teague. Phone: (301) 286-4232; FAX: (301) 286-9803.
- August 31-September 3 COSPAR Symposium on Global Change and Relevant Space Observations, Washington, D.C., World Space Congress. Contact J. Fellows/OMNET; FAX: 33 1 45087867; Telex: 214674; Phone: 33 1 45087648. (Call for papers available from World Space Congress, AIAA, The Aerospace Center, 370 L'Enfant Promenade, S.W., Washington, D.C. 20024-2518; Phone: (202) 646-7451; FAX: (202) 646-7508.
- October 12-16 Workshop on Synthetic Aperture Radar System and Its Application in Natural Resources, ITC, Enschede, The Netherlands. Contact Dr. Yousif Ali Hussin, ITC, 350 Blvd 1945, P.O. Box 6, 7500 AA Enschede, The Netherlands. Phone: (31)(53)874-444; Telefax: (31)(53)874-400 or (31)(53)874-399; Telex: 44 525 ITC NL.

The Earth Observer

- November 2-6 Sixth Australasian Remote Sensing Conference, *Remote Sensing and Spatial Information*, Michael Fowler Centre, Wellington, New Zealand. Contact Stella Belliss, DSIR Physical Sciences, P. O. Box 31-311, Lower Hutt, New Zealand; Phone: +64-4-5666919, extension 8693; FAX: +64-4-5690067.
- December 4-6 Computer Science for Environmental Protection 6th Symposium, Munich Germany, sponsored by German Computer Soc. Contact Siemens Nixdorm Information System. Phone: 49 89 636 48466.
- December 7-11 American Geophysical Union Fall Meeting, Civic Auditorium/Brooks Hall, San Francisco, California. Contact Karol Snyder. Phone: (202) 939-3205 or 1-800-966-2481; FAX: (202) 328-0566.
- December 8-12 Natural Hazards Induced by Environmental Changes Int'l Conference, (Zurich) Davos, Switzerland. Sponsored by European Foundation Commission of European Communities. Contact Dr. Josip Hendekovic European Science Foundation, 1 quai Lezay Mamesia, F-67000, Strasbourg, France.
- 1993 •
- February 8-11 Ninth Thematic Conference on Geologic Remote Sensing: *Exploration, Environment, and Engineering*, Pasadena, California. Contact Nancy Wallman, ERIM, Box 134001, Ann Arbor, MI 48113-4001. Phone: (313) 994-1200, ext. 3234; FAX: (313) 994-5123; Telex: 4940991 ERIMARB.
- April 4-8 25th International Symposium on Remote Sensing and Global Environmental Change, Graz, Austria. Contact: Robert H. Rogers, ERIM, P.O. Box 134001, Ann Arbor, MI 48113-4001. Phone: (301) 994-1200, ext. 3382; FAX: (313) 994-5123.
- April 19-23 Call for Papers, First Thematic Conference, International Symposium "Operationalization of Remote Sensing." ITC, Enschede, The Netherlands. Contact: Prof. J.L. Van Genderen, ITC, P.O. Box 6, 7500 AA Enschede, The Netherlands. Phone: 31-53-874 254, FAX: 31-53-874 436, Telex: 44525 ITC NL.

The Earth Observer

The Earth Observer is published by the EOS Project Science Office, Code 900, NASA/Goddard Space Flight Center, Greenbelt, Maryland 20771, telephone: (301) 286-3411, FAX: (301) 286-3884. Correspondence may be directed to Charlotte Griner at the above address. Articles, contributions to the meeting calendar, and suggestions are welcome. Contributions to the meeting calendar should contain location, person to contact, and telephone number. To subscribe to The Earth Observer, or to change your mailing address, please call Linda Carter at (301) 513-1613, or write to the address above.

The Earth Observer Staff:

Executive Editor: Charlotte Griner
Technical Editor: Renny Greenstone
Managing Editor: Winnie Humberson
Assistant Editor: Judy Laue
Distribution: Linda Carter

Code 900
National Aeronautics and
Space Administration

Goddard Space Flight Center
Greenbelt, Maryland 20771

Official Business
Penalty for Private Use, \$300

Postage and Fees Paid
National Aeronautics and
Space Administration
NASA-451

