

PI: Abe Falcone
(Penn State University)

Team: Ian Ashcroft, Michael Betts, Bill Bevidas, Brynn Bortree, David Burrows, Zachary Catlin, Joseph Colosimo, Sierra Deppe, Tim Emeigh, Tom Forstmeier, Derek Fox, Killian Gremling, Md. Arman Hossen, Katie McWhirter, Kadri M. Nizam, Laurel Oneill, David Palmer (LANL), Abigail Raytsis, Lukas Stone, Mitchell Wages, Daniel Washington, Mike Zugger

BlackCAT Overview

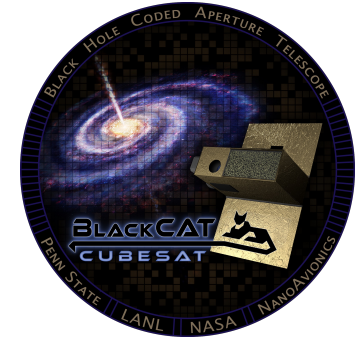
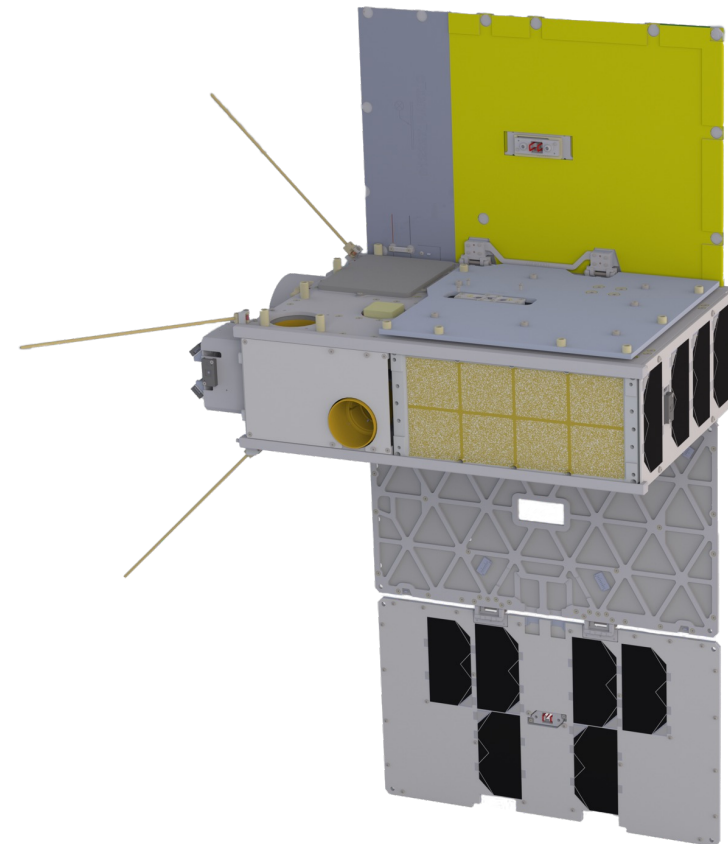

Table 1. Mission overview	
Instrument	Soft X-ray (0.5-20 keV) coded mask telescope with hybrid CMOS detectors ~0.85 Sr FOV ~40" position centroiding (bright GRBs)
Spacecraft	Standard 6U CubeSat
Launch	Expected launch: Jan 11, 2026
Orbit	Sun-synchronous LE orbit
Science	Detection of EM counterparts of high redshift GRBs (enabling studies of star formation rate and properties), gravitational wave counterparts, and x-ray transients WFOV monitoring and rapid alerts for multi-messenger follow-up
Technology	Soft X-ray coded aperture mask Demonstrate latest X-ray Hybrid CMOS detectors in-orbit





Collaborator Acknowledgements:

Kongsburg NanoAvionics provided our spacecraft bus and has worked with us as a team

Teledyne and Penn State have had a longstanding detector development relationship, and these engineering-grade detectors have been adapted for flight

Luxel worked with us to provide a novel x-ray coded mask with an integrated optical blocking filter

Thanks !!



Also, many thanks to NASA!!

This **low-cost program to fly CubeSats within APRA** is a critical method for enabling:

- 1) **space-flight technology development** that couldn't happen on larger missions
- 2) Hands-on experience and leadership **experience in space-flight programs for students, postdocs, and early career researchers**

BlackCAT Tech Dev Motivation

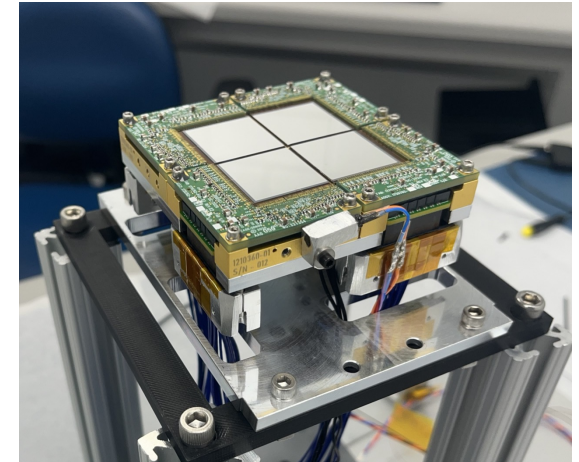
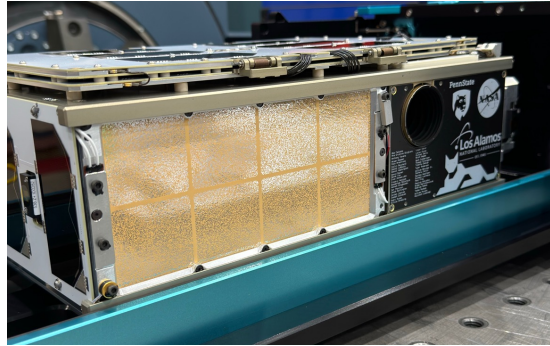

Astro2020 Decadal Review Panel prioritized the following:

- a) **Time-domain astronomy**
- b) Astrophysical science that could be achieved by a ***future large X-ray mission*** (Lynx-like) and/or upcoming **X-ray probe-class X-ray mission**
- c) **enabling X-ray technology** for flagship of the following decade and/or upcoming time-domain X-ray missions

X-ray hybrid CMOS detectors can enable the paths above that require large-format Megapixel detectors, with fast readout and/or fine angular resolution

(along with low-power and radiation hardness)

BlackCAT is advancing these X-ray hybrid CMOS detectors for larger missions (e.g. Lynx) and/or future arrays of CubeSats (e.g. BlackCAT-10)

BlackCAT is also advancing a new type of X-ray coded mask, made by Luxel



BlackCAT Science

The BlackCAT CubeSat is a soft X-ray sky monitor, transient finder, and gamma ray burst detector providing rapid alerts and time-resolved X-ray data for high-energy and multi-messenger astrophysics

- **Soft X-ray response with wide-FOV** is tuned to discover **high-redshift Gamma Ray Bursts** and probe the epoch of **cosmic star formation** in the early universe
- locate potential electromagnetic **counterparts of gravitational wave events** with arcminute accuracy (as well as multi-messenger events such as HE neutrinos)
- **Monitor the transient sky** and trigger **rapid alerts** from Galactic transients, blazars, Short GRBs, tidal disruption events, XRFs, supernova shock breakouts, etc. using wide sky nearly continuous X-ray monitoring

High redshift GRB Science w/BlackCAT

Measure the cosmic star formation rate over $5 < z < 12$ by detecting and observing high-redshift gamma-ray bursts and their afterglows.

- *Single module* will detect many bursts at $z > 4$, and could detect $\sim 1/\text{year}$ at $z > 8$ (more modules would enhance rates)
- redshift derived from ground follow-up data
- Burst redshifts will provide data for determining the cosmic star formation rate over $5 < z < 12$
- Stellar light was likely the dominant cause of the cosmic reionization
- Star formation estimates are crucial to constructing a full picture of reionization
- Recent JWST results imply current star formation rates at high redshift may be underestimated
 - **BlackCAT measurements of stellar death at high redshift could be even higher than expected and enlightening**

Peak energy for high-z GRBs is redshifted to X-ray band

→ **BlackCAT has selection effect to find cosmological high-z GRBs**

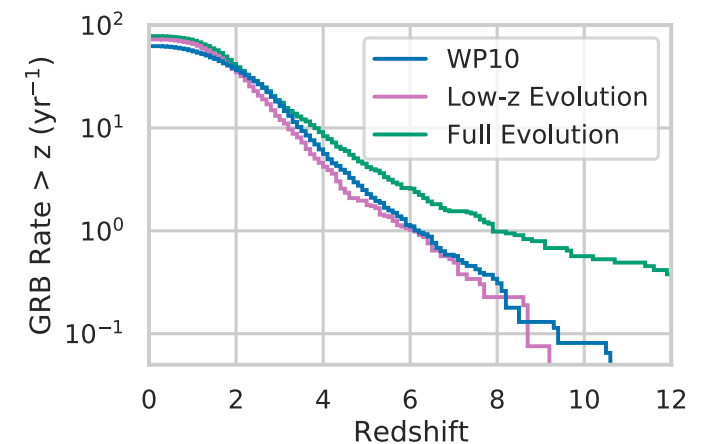
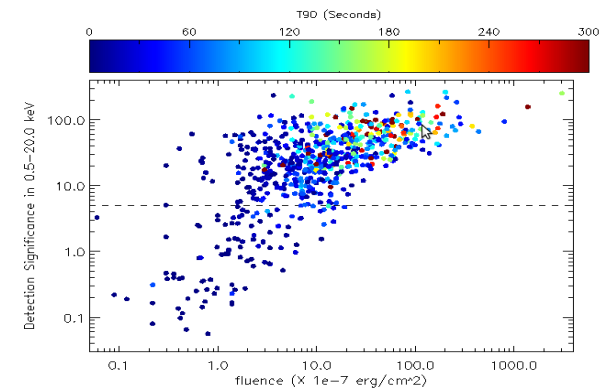

BlackCAT Transient Survey



BlackCAT will also survey the sky and produce light curves (0.5-20 keV) of hundreds of transient X-ray sources

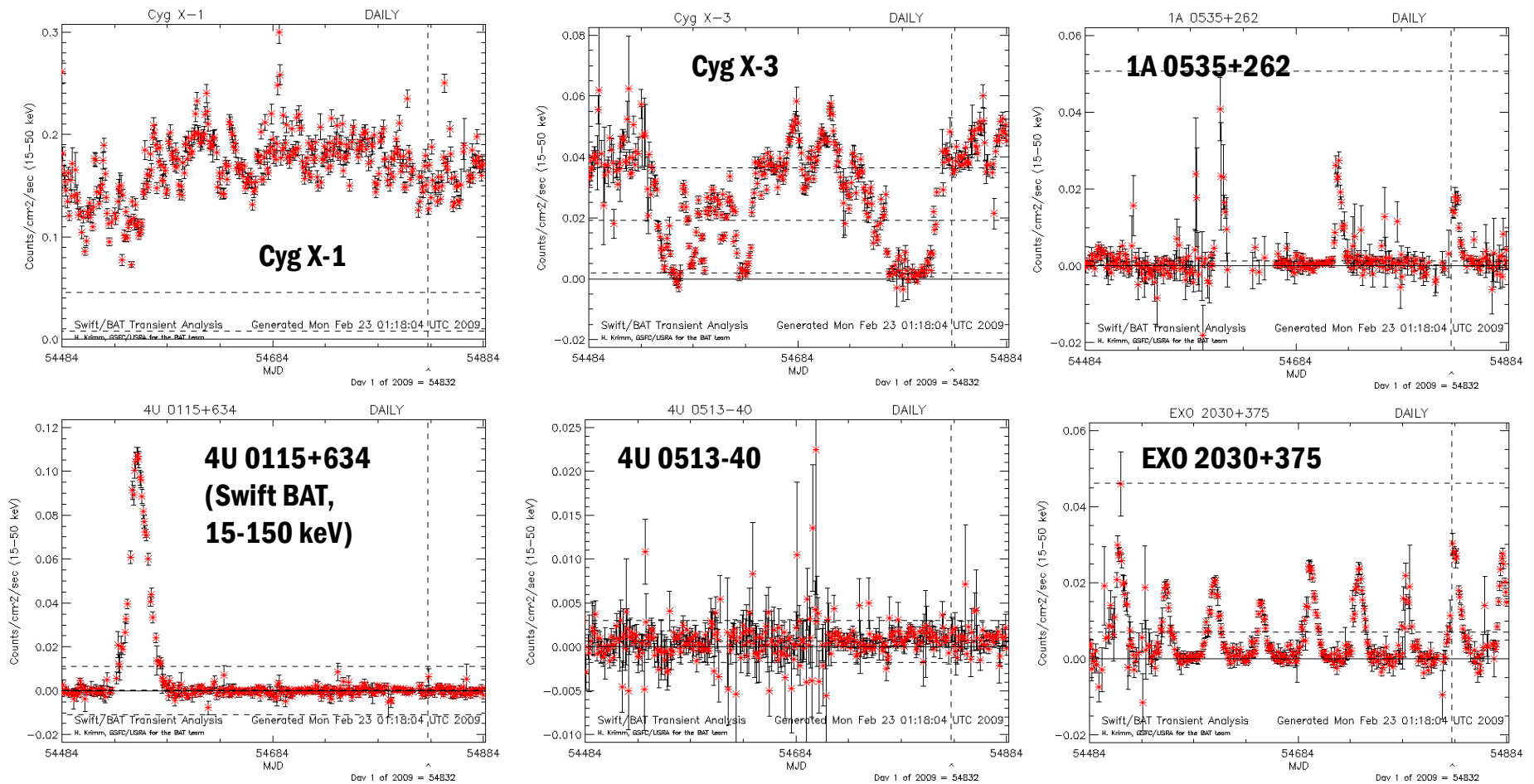

Response and localization



- BlackCAT detects and localizes Gamma Ray Bursts, transients, and potential GW counterparts
 - determines GRB position onboard to ~40" for bright GRBs/sources (and ~60-90" for threshold detections)
 - Rapidly (~30 seconds) sends position to S/C and to ground with Iridium network using Nearspace Eystar S4
 - telemeters light curve and spectral info

Simulated BlackCAT GRB Image

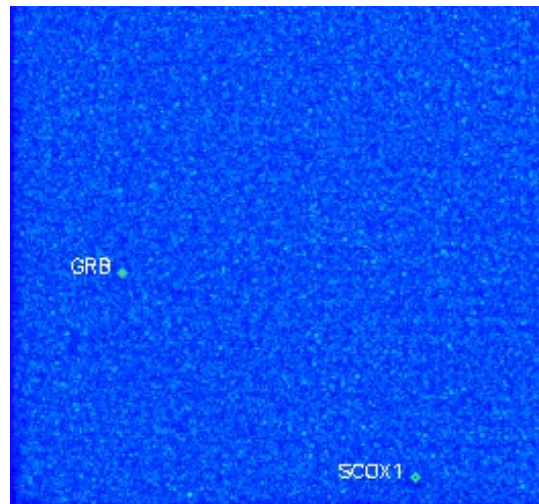



Coded Mask Imaging

Coded Aperture Mask + Silicon Hybrid CMOS Detectors

Source 1

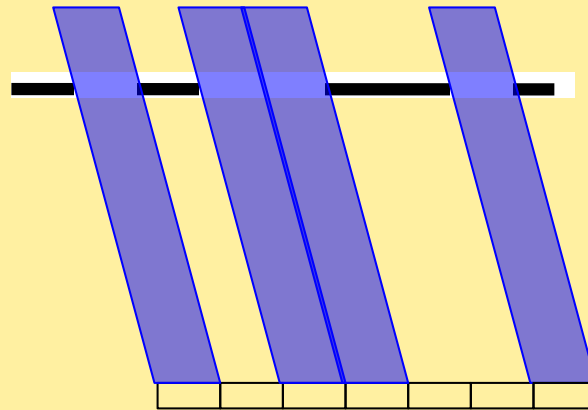

*Same technique as INTEGRAL
IBIS and Swift BAT, but at
lower energies.*

- Mask pattern casts X-ray shadows on detector for $E < 20$ keV.



Coded Mask Imaging

Coded Aperture Mask + Silicon Hybrid CMOS Detectors

Source 1 **Source 2**

*Same technique as INTEGRAL
IBIS and Swift BAT, but at
lower (soft X-ray) energies.*

- Mask pattern casts X-ray shadows on detector for $E < 20$ keV.
- Deconvolution of detector image with mask pattern produces sky image

Imaging is a multi-step process using the same sophisticated algorithms used by the *Swift* BAT:

- Reconstruct sky image from projection on hybrid CMOS detector pixels, applying 2D convolution through mask

Detectors

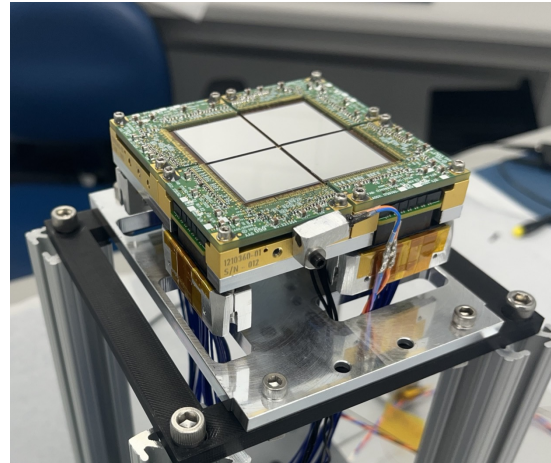
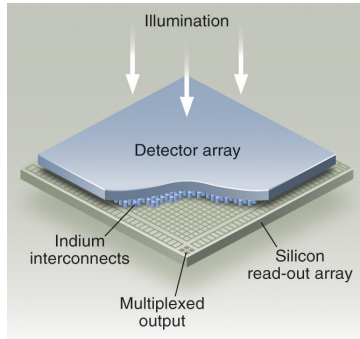

4 Packaged Speedster-EXD550 detectors mounted in BlackCAT focal plane array configuration

- Each focal plane detector consists of 4 Si hybrid CMOS detectors (Speedster-EXD550's)
- The intrinsic pixel pitch is 40 μm
- passively cooled to below $\sim -40\text{ C}$ to achieve sufficiently low dark current
- While these detectors are very fast, they have higher read noise than our best hybrid CMOS detectors (which we hope to fly on a future mission)

Parameter	Value
Type	Si Hybrid CMOS
Absorber material	Silicon
Absorber thickness	100 μm
Detector Format	550 x 550
Readout	Sparse Event-Driven, digital
Frame rate	150 frame/sec (full mode) 1-10 kHz (sparse mode)
Pixel Size	40 x 40 μm
Software binning	8 x 8
Power	$\sim 300\text{ mW}$
Operating Temp.	$\leq -40^\circ\text{ C}$
Time resolution	0.1-10 msec

Speedsters: Event Recognition

- Typical X-ray detectors, like CCDs, readout of entire image and off-chip extraction of X-ray events.

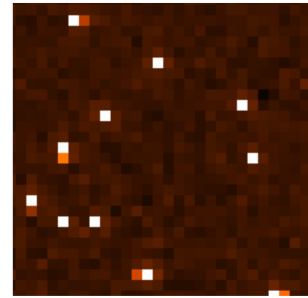

Left: CMOS lab data
XRT data

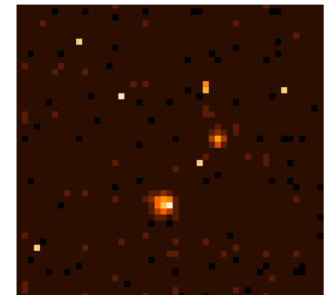

Right: Swift
XRT data

- The Speedster, with sparse readout, reads out only the pixels containing X-ray events.

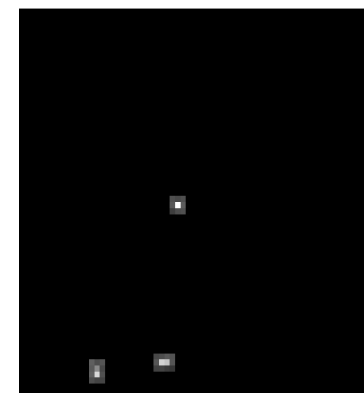
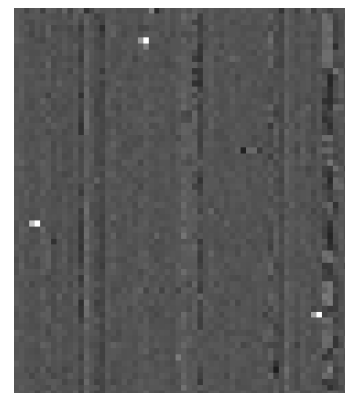
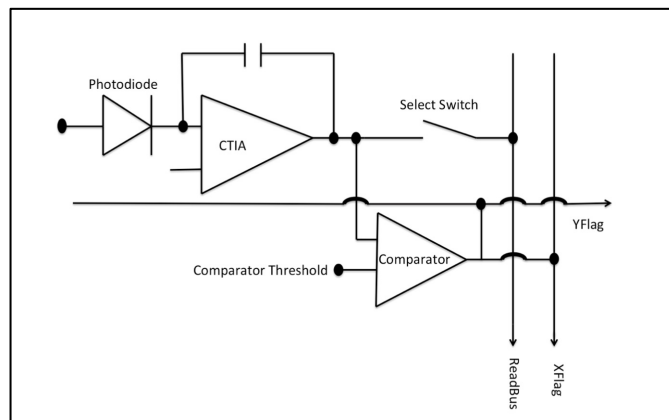

.... And it is fully digital-out

Electronics: Payload Interface Board

Our **custom-built electronics** controls and reads the focal plane array, while also performing **on-board imaging and onboard triggering** (similar to Swift BAT)

Sends data to spacecraft for telemetry

Sends **trigger alerts** to the Eystar S4 board for **rapid alert notification through the Iridium** network

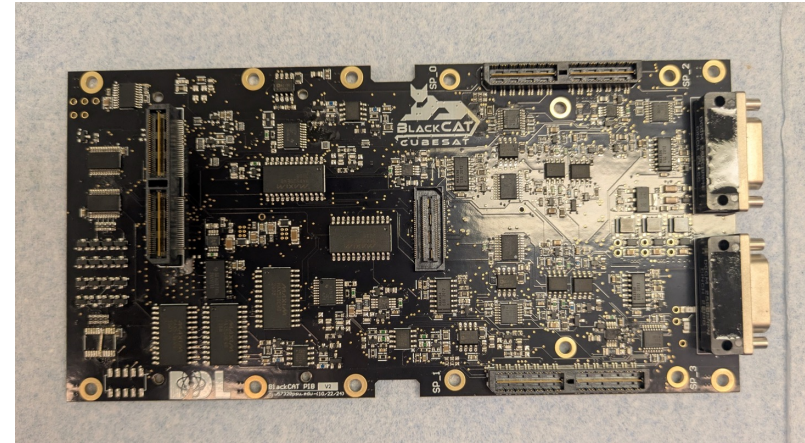

PIB Main Board

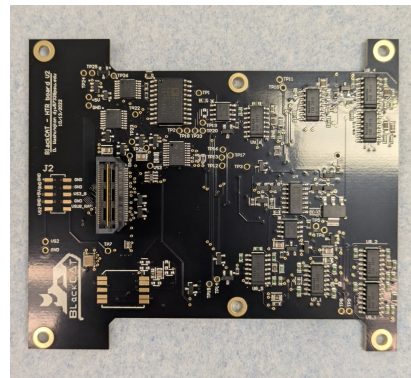

HTR Daughter Board

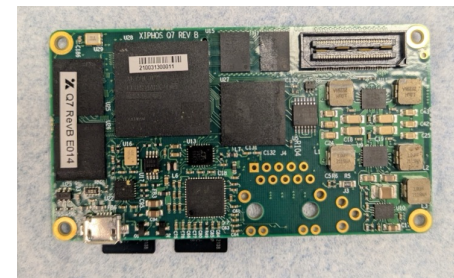

Xiphos Q7S Daughter Board

BlackCAT Status:

- Launched Jan 11, 2026 in ~600 km Sun-Synch Polar orbit
- daily S-band comms within 1 day of launch and continuing today

Integration activities and thermal vac activities

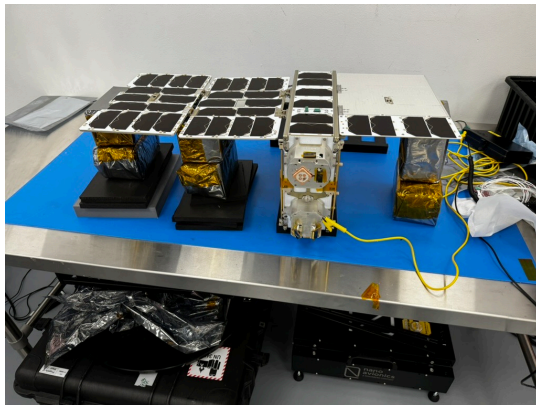
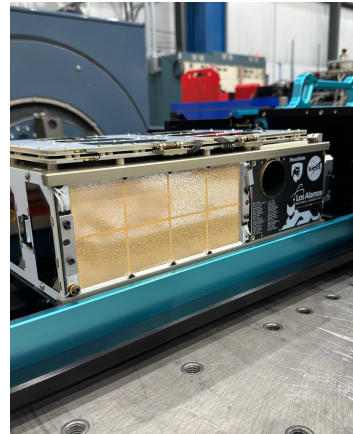
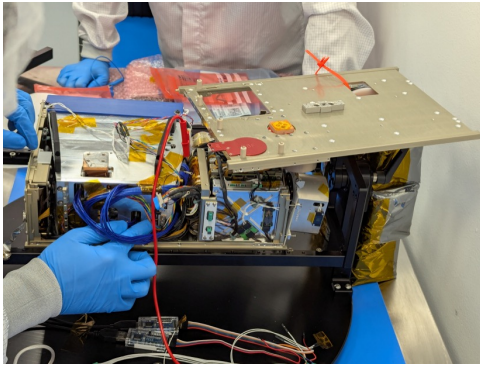

ready for launch

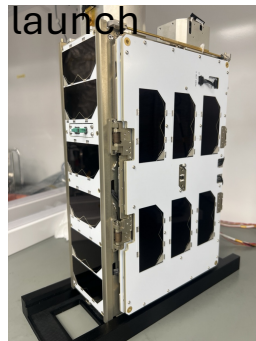

Deployment in orbit:



Spacecraft commissioning completed end of March

Payload commissioning ongoing:

X-ray First light April 18

First 'Reconstructed Image' Light on May 13, 2026

BlackCAT Status:

Payload commissioning ongoing

X-ray light in April and **First Reconstructed Image Light** in May 2026

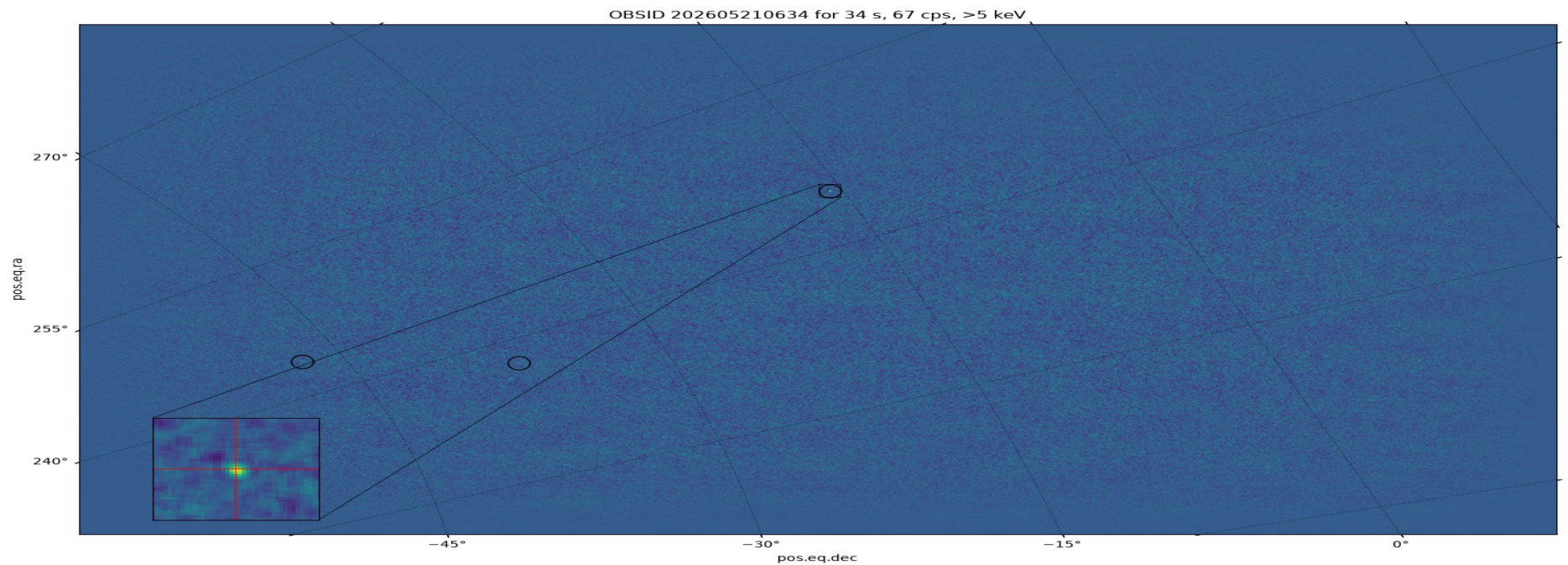
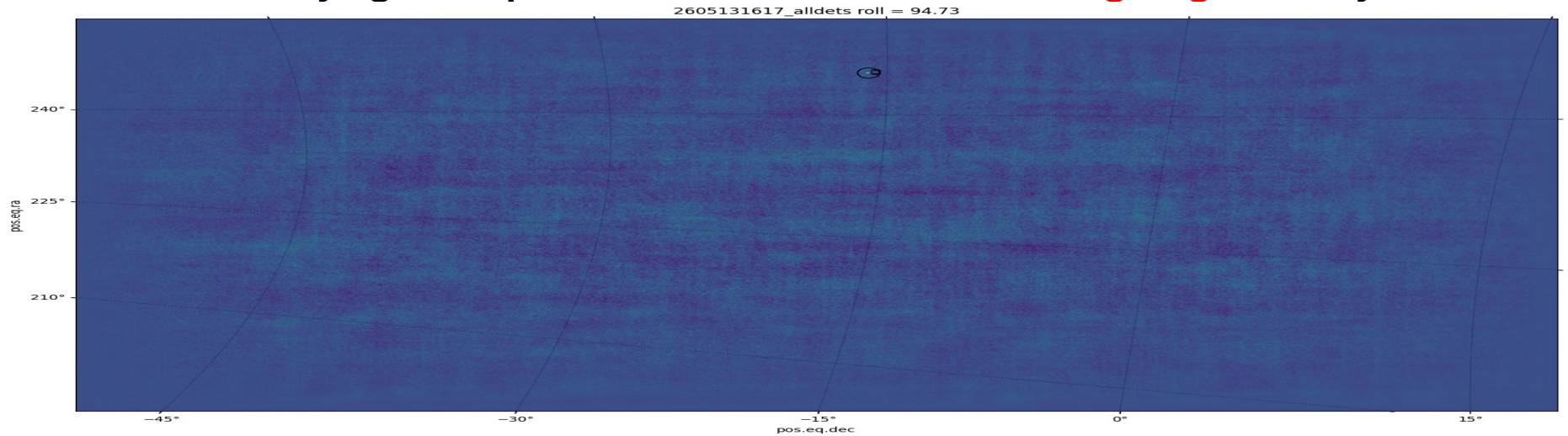

The Future: BlackCAT-10

Parameters & Requirements

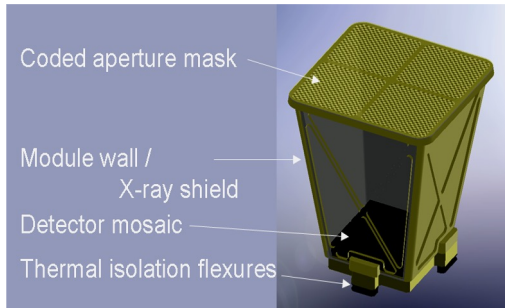

× **10**

- N Independently flying identical modules ($N = 6 - 12$)
- Each module contains a coded mask in front of an array of 4 Si hybrid CMOS detectors

Parameter	BlackCAT single module
Bandpass	1 – 20 keV (goal 0.5-20 keV)
FoV	0.9 sr (~3.5 sr for 6 modules with anti-Sun offsets)
Angular Resolution	6.3 arcmin (FWHM)
Position Accuracy	1 arcmin (30 arcsec for bright GRBs)
Module opening area	17.0 x 8.8 cm
$\Delta E/E$	<5% at 5.9 keV (goal of <3%)
Δt	~7 msec (or as low as 0.1 msec)
DXRB rate	~ 540 cts s ⁻¹
Internal Bkgnd	< 1 cps
Pt Src Sensitivity	~ 240 mCrabs (7σ , 30s, 1 module)

EXTRA



Coded Mask

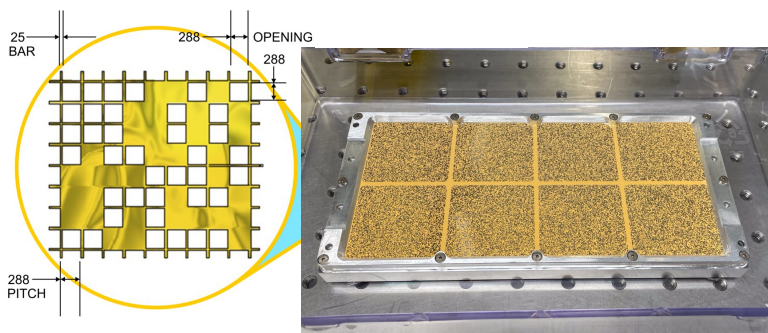

Mask fabricated by Luxel.

Has been vib tested, acoustic tested, and has completed thermal vac testing.

- The mask consists of a ribbed frame that supports electroformed Nickel coated with gold
- Closed cells have 17 μm of Ni plus 8 μm of Gold (4 μm on each side)
- Module walls provide X-ray shielding from sides
- Mask pitch of 320 μm

Table 2: BlackCAT Mask Parameters	
Parameter	Value
Focal Length	158 mm
Mask size (aperture)	176 x 80 mm
Mask element	320 x 320 μm
Detector superpixel (8 x 8 pixels)	320 x 320 μm
DM FOV (partially coded)	0.85 sr
Mask Transmission	>40%
Image Scale	52"/pixel
	6.9 arcmin/superpixel